

Vol. 55 No. 3 August 1991



# Chemistry

IN NEW ZEALAND

## Way out in front: 670 Titroprocessor



## COVER STORY

# SEE YOUR TITRATIONS IN A NEW LIGHT — 670 TITROPROCESSOR

### **Automation takes pride of place here**

The new 670 Titroprocessor opens up new possibilities for your titrations: you yourself design your method procedure, including all auxiliary functions.

This gives you direct control over, for example, the sample changer. Direct means that an additional control unit is no longer necessary — it is integrated in the 670 Titroprocessor. Direct also means that you can perform sample transport just when and how you like.

Not only sample changers, but also all other auxiliary functions can be controlled directly: do you want to add solvents or determine individual measured values during a method at a particular time? Then go right ahead — with the 670 Titroprocessor.

### **Wide range of application and evaluation possibilities**

The 670 Titroprocessor offers incremental titrations with variable or constant volume steps (dynamic or monotonic titration). The measured value transfer in these titrations is either drift-controlled (equilibrium titration) or effected after a fixed waiting time. Pk determinations and fixed end-points (e.g. for specified standard procedures) are naturally included.

An efficient end-point titration for rapid routine determinations is also at your disposal.

Sixteen freely-programmable computational formulae with assignment of the calculation parameters and units, mean-value calculations and arithmetic of one titration to another (via common variables) are available. You can thus perform your result calculations without any limitations.

### **Designed for automation**

In addition to the free control possibilities of the 670 Titroprocessor, the 4 titration burettes, numerous auxiliary dispensers and 2 independent measuring inputs (expandable to 8 measuring inputs) enable you to perform several different determinations with one and the same system, all without manual intervention.

### **Methods are more than just titrations**

You can also use the 670 Titroprocessor to solve complex analytical tasks: In addition to various auxiliary functions, which you can freely program, you can perform up to 4 different titrations on a single sample.

Methods development and optimization also receive effective support from

the 670 Titroprocessor. Full use is made here of the advantages offered by the screen: during the titration you see the titration curve [live] on the screen and you can intervene and change parameters should it be necessary.

When a method has been developed and optimized, it can be stored in the method memory under its complete title thanks to the typewriter keyboard, e.g. [determination of common salt].

### **Complete documentation**

Is provided by the built-in printer/plotter, incl. titration curves (original and derived) in DIN A4 format. Yet another case where you will appreciate the advantages of the complete typewriter keyboard: your own texts to identify samples, as result assignments or as general remarks can be printed out; you can even document detailed comments in this manner.

*For further details contact:*  
Peter Ellingham  
of John Morris Scientific Ltd  
Phone 444-5836  
or TOLL FREE 0800 651-700  
(Fax 444-0974)

# LETTER FROM THE PRESIDENT (AUGUST 1991 ISSUE)

VOL 55 (3) JULY 1991

CONTENTS

Dear Member

In my final letter to you before my Presidential term finishes on 1 September I would first like to say that it has been a privilege and a pleasure to lead the Council we have had this year, to interact profitably with our increasingly experienced and well-run Secretariat, and most importantly, to visit the Branches and meet with members all round the Country.

I can now confirm (see previous Letter from the President) that NZIC has now been invited formally to co-sponsor the 1995 International Chemical Congress of Pacific Basin Societies (PACIFICHEM Congress). The institute has accepted sponsorship and Dr Brian Halton will be our official representative on the organising committee. This initiative will not involve substantial expenditure but will certainly boost the profile of New Zealand chemistry.

As I have said before Specialist Groups are a very important component of the Institute's activities. In recent years communications between Council and Specialist Groups have become rather tenuous and relations have sometimes suffered accordingly. Last year Council moved to improve communication with the Specialist Groups by appointing a Councillor to act as a liaison person. Council has now had drawn up a discussion paper on the relationship between Council and Specialist Groups which has been circulated for comment by the Groups and also the Branches. With goodwill on both sides it is expected that workable and mutually profitably operational guidelines will be able to be formalised at the August 1991 Council meeting.

As mentioned previously there will be no Annual NZIC Conference in 1992. It will resume in Auckland in 1993 but for 1992 the best option is for NZIC members to attend the Ninth National Convention of the RACI being held at Monash University, Clayton, Victoria from 28 September-2 October 1992. The Australians are very keen that a good contingent of New Zealanders attend their convention since it will mark the 75th anniversary of the founding of RACI Divisions to contact the corresponding NZIC Specialist Groups to involve the latter in the Convention programme. A "First Announcement" on the Convention is published elsewhere in this issue of the Journal.

I would like to add that the NZIC Council is also supporting in 1992 the Eighth Australasian Electrochemistry

(Continued on Page 3)

<b>Editorial</b> .....	39
A letter from the President.	
<b>Fats</b> .....	40
A neglected chapter in nutrition.	
<b>60th Jubilee Conference</b> .....	46
26-28 August 1991, University of Canterbury, Christchurch.	
<b>Annual Report for 1990/91</b> .....	47
<b>Public Affairs Submissions &amp; Reports</b> .....	49
<b>New Generation On-Site Nitrogen Systems from NZIG</b> .....	53

**Editor:** R.B. Hall, 64 Mellons Bay Rd, Howick  
Phone: 09 534-9109

**Publisher:** Michael Pervan Holdings.  
PO Box 68-499, Newton, Auckland

**Advertising:** Carl Roze, Ph: 09 521-5151  
PO Box 87-102, Meadowbank, Auckland

**Branch Editors:**

**Auckland:** Dr. Robyn Somerville, Mt Albert Research Centre DSIR, Private Bag Auckland.

**Waikato:** Ron Newth c/- Chemistry Dept, University of Waikato, Private Bag, Hamilton.

**Manawatu:** Dr. Daryl Rowan, Biotechnology Division, DSIR, Private Bag, Palmerston North.

**Wellington:** Adrian Bennett, BRANZ, Private Bag, Porirua.

**Canterbury:** Dr. Robert J. Martyn Chem. Division, DSIR, PO Box 29-181, Christchurch.

**Otago:** Dr. George Emerson, Bio-Chemistry Department, University of Otago, PO Box 56 Dunedin. Published on behalf of the New Zealand Institute of Chemistry (Inc.) PO Box 12-347, Wellington.  
Ph: 04 739-444. Fax 04 732-324

President: Dr H.J. Percival Hon. Gen. Secretary/Executive.

Officer: Alan A. Turner Hon. Treasurer: D.P. Karl.

**Chemistry in New Zealand:** Published six times a year in February, April, June, August, October and December.

**Editorial:** Technical and scientific articles should be submitted to the editor no later than 1st of the month of publication. The editor will always welcome commercial and industrial news on product design, development and testing, processing techniques, company and personal news etc.

**TITROPROCESSOR**  
The Methrohm 670 Titroprocessor can perform virtually any conceivable potentiometric titration. Should your method, for example, comprise two titrations, you can, if necessary, titrate very slowly until the first endpoint is reached, then add a starting volume to save time and continue the titration at normal speed.  
Equipped with ready-to-use methods for routine titrations for example: Acid/base titration, TAN/TBN (Total acid/base number) in oils, Chloride determination, COD determination in water samples, Detergents in soaps, Diazotization titration, Peroxide number in edible fats and oils.

# FATS A NEGLECTED CHAPTER IN NUTRITION

1990 Mellor Lecture to Wellington Branch N.Z.I.C.

By F. B. Shorland, School of Biological Sciences, Victoria University of Wellington.

## 1. A Tribute to J. W. Mellor (1869-1938): Methodology of His Success.

In thanking the Wellington Branch for the invitation to give this lecture it is my pleasant duty to remind you of Mellor's achievements. These have been well described by Askew (*N.Z. Science Review* 1952, 10, 148.) who indicated that all are acquainted with his Modern Inorganic Chemistry and his treatise on Inorganic and Theoretical Chemistry. I would doubt, however, if more than a handful of scientists would have read all of its 16 volumes on which he laboured between 8pm and 2am each night for almost 20 years; the volumes appearing from 1922-37. Rather than go into ecstasy about Mellor's work the time has come to ask why he was successful so that later generations can follow in his footsteps.

Many of our best scientists, including Robertson and Hudson, were mature in their field while still in their teens. The process of starting young is recognised in athletics and in rugby: there the approach is scientific. In chemistry the approach is haphazard. As with great musicians, to become a virtuoso chemist one needs to become self driven and obsessed with the subject at an early age. If you wait for others to teach you your initiative will be destroyed. Mellor was on the way at 13. At some later stage it becomes appropriate to meet the giants.

At the NZIC Conference in 1948 I gave a paper on "The Education of the Chemist: The Research Workers' Needs (*N.Z. Science Review*, 1948, 6, 114-118)". In dealing with the research workers' needs the Mellor and Rutherford examples showed that it was perhaps inappropriate to provide equipment lavishly to the commencing researcher.

In receiving the Nobel prize in Chemistry Lord Rutherford said he learnt more of research methods in those first investigations at Canterbury University College, under somewhat more difficult conditions than in any work he had done since. Mellor left school at 13 years becoming a boot clicker in Dunedin. After work he carried out experiments in a six foot by six foot shed. Too poor to buy the books he wanted, he borrowed, and laboriously copied out the contents by long hand. Who is to say that this hard type of education did not produce outstanding results?

At the time when I gave the paper some highly paid academics complained that it was uneconomic for them to have to copy out by hand long lists of names. When staff are relieved of such tasks the time will come to discuss research. Poor pampered pups! Other academics regardless of work load did some good research. Robertson at VUW with a few bottles, some chemicals and a thermostat did significant work on the mechanism of halogen addition and substitution. Still others thought that university was merely a high class secondary school which was the way K. Popper found it at Canterbury University College where his world famous works on the philosophy of science were far from appreciated. Fortunately our universities have changed a lot since then.

Mellor had the image of becoming the foremost chemist of his time against all odds by studying and experimenting in his shed each evening. This attracted the attention of the late G. M. Thomson, science master at the Otago Boys' High School. Mellor attended classes at the Technical High School of which G. M. was a director, and from there he matriculated in 1892. By this time he had shown an aptitude for mathematics also, and Thomson, recognising a coming genius, arranged a scholarship to the university. Here Mellor achieved successively in chemistry, senior scholarship (1897), first class honours (1898), and the 1851 Exhibition Scholarship. A fine work on Higher Mathematics for

students of Chemistry and Physics was published in 1902. After teaching at Lincoln College for a few months Mellor sailed from Port Chalmers with his wife in August 1899, to take up his research scholarship at Owens College, Manchester, under Professor H. B. Dixon.

In 1902, Mellor, now a D.Sc. was appointed chemist to the Pottery Manufacturers' Federation, in Newcastle-under-Lyme, eventually becoming director of the research laboratories of the Federation. When the war came Mellor offered his services to the steel industry where he replaced the German scientists upon whom the steel industry had relied. The results of his research enabled the industry to meet the crucial demands of war without delay. He was offered a peerage but claimed his health prevented acceptance. When the British Refractories Research Federation was formed to include the Pottery Manufacturer's Research Association Mellor was appointed to direct the magnificent Mellor Laboratories of the British Refractories Research Association set up in 1934. He was made a Fellow of the Royal Society in 1927. He retired in 1937 on account of continued ill health and was awarded a C.B.E.: a barren honour for so great a man.

Here I mention his scientific achievements only. His writings contain a wealth of quotations denoting familiarity with English literature, prose and poetry as may be gleaned from the publication entitled "Uncle Joe's Nonsense" and from letters to nephews and nieces in Dunedin and to friends. After disposing of 30,000 volumes, there still remained 8 tons of books to transport to London. In today's world young students are likely to become brain damaged through continued exposure to television, and, or, head phones which can also damage hearing. At the same time the public perception of science is based largely on misinformation given out by the mass media. My impression is that the total amount of intelligence around is quite substantial; we simply don't know how best to tap it.

In my college days I divided the students up into morons and geniuses. I believed the latter when they told me that they never did any swot. Later I discovered that they were lying and that in fact they worked like mad. I then did the same and got a similar result. The main problem for the many, but not for the few, is the absence of life after birth without which you cannot hope to succeed.

## 2. Fats: A Neglected Chapter in Nutrition

No subject has been less well understood than the nutritional effects (positive and negative) of dietary fats. This situation arises from the lack of knowledge of the diversity of the fatty acid components and especially of the eicosanoid metabolites which may have different and even opposing nutritional properties. To understand the nutritional properties of fats it is essential to unravel in detail their chemical make-up; even the position of the fatty acid on the glyceride molecule alters their nutritional qualities. Already a few workers in the field are beginning to understand the problem and their researches have borne fruit. It turns out that fats play an unexpectedly important role in the control of chronic diseases, including coronary heart disease (CHD), cancer and diabetes. However, these developments are generally ignored by the public and even by those who are responsible for health and education.

It is hoped that this presentation will provide a picture of the role of fats in nutrition as currently revealed by the scientific literature.

## The Confused State of Knowledge of the Role of Fats in Nutrition

Historically *Leviticus* 2, 23 forbade eating beef, mutton and goat fats; nevertheless, the father (to welcome back the prodigal son) killed the fatted calf. To add to the confusion US Federal Authorities, since 1917, recommended fat (and sugar) as welcome additions to the diet without limit as to intake. However, the Surgeon General's (1988) Report<sup>1</sup> recommended "an overall reduction in fat consumption, especially saturated fatty acids, as the primary dietary priority for improving the health of Americans."

The above is a prime example of lipid illiteracy. Eskimos in their native state had no chronic diseases (*Lancet* Editorial, 1983)<sup>2</sup> despite the intake of nearly 50% fat calories. This illiteracy extends to almost all organisations and professions dealing with health. In chemistry departments of most universities fats are at the bottom of the totem pole. Academics, as a rule, could not describe the structure of a polyunsaturated fatty acid let alone show that in a mixed triglyceride, positions 1, 2 and 3 are distinguishable. Even fat specialists tend to remain ignorant of aspects of work critical to the advancement of their researches.

According to Dr J. T. Craig, Senior Lecturer in Chemistry at VUW, out of a class of 300 this year only one answered correctly an exam question dealing with the hydrolysis of fats. I hasten to add, however, that a Biochem. 111 student told me that the clotting factor in coronary heart disease (CHD) thromboxane A<sub>2</sub> was produced in the blood platelets from its omega 6 or n-6 (linoleic acid) precursor.

Dr Margarét Gordon, on leave from the School of Biological Sciences, VUW, kindly sent me a pamphlet from the prestigious NRC Atlantic Fisheries Research Laboratory, Halifax, Canada. On the cover are key references to the role of omega 3 or n-3 acids in fish in the prevention of CHD. Inside, however, the fish recipes demonstrate a lack of understanding of the material in the references. In the first recipe 1 kg of fish is cooked with 125g vegetable oil (which typically contains 50-60% n-6 fatty acid and therefore is tendentially thrombotic (or the opposite to n-3).

The second recipe involves the addition of a cup of green grapes with half slivered toasted almonds (rich in n-6) which is less objectionable as almonds are probably there as a garnish. In the third recipe no oil is added. Similarly in 10 out of 12 recipes of the NZ Heart Foundation (NHF N043/1986) fish is cooked in polyunsaturated oil. The authorities here generally believe that lowering serum cholesterol with polyunsaturated oils or other agents will reduce the death rate from CHD. However, none of the massive experiments on lowering serum cholesterol significantly reduced the death rate from CHD.

The confused state of knowledge of the role of fats in nutrition may extend even to specialists who are invited to review the subject in international reviews. This confusion arises from the fact that the subject advances along separate channels. The specialists tend to select (almost inevitably) views that fit their preconceived theories. In my relatively recent experience at Michigan State University Professor A. M. Pearson at MSU kindly invited me to contribute to a review<sup>3</sup> on "warmed over flavour". This is concerned with the rapid rancidification of cooked or minced meat compared with the whole intact meat. I knew little about the subject then. My job was to provide background information needed to explain the nature of the phenomenon.

Collaboration with such reviewers indicates that they are likely to be daunted by the volume of available literature. In the struggle to make a credible review, material which makes sense to them will naturally be selected. This state of affairs may relate to the fact that scientists are almost forced to concentrate on aspects that make sense in terms of their specialised knowledge. I am not surprised, therefore, to find in *Science*<sup>4</sup> recently that 55% of papers indexed by an institute over the period 1981-1985 received no citations. The conclusion that all such papers are useless is nonsense. Important concepts like Mendel's law or Glinka's observations on climate and soil type were not recognised until long after their publication. A scientist once said to me "Shorland that was a great paper you published in *Nature*". I replied "What was it about?" He replied "I have no idea". Readers all too often are driven by their specialised interest and peruse rather than read the literature.

(Continued from Page 1)

Conference which will be held 10-14 February in Auckland. The Electrochemistry Specialist Group (which will become part of the new Physical Chemistry Group) has the major role in organising this Conference, coordinated by Dr Graham Wright, University of Auckland.

Finally, I would like to mention that the top priority issue for the Institute for the rest of 1991 is the future of our Journal "Chemistry in New Zealand". With some of the difficulties experienced this year, particularly with a forced change in publisher (see 1990/91 Annual Report), and the agreement in the NZIC/RACI Memorandum of Understanding (also see Annual Report) to consider a joint NZIC/RACI journal this matter has become very important and needs resolution. Substantial debate has taken place amongst Council members and Branch members (including discussions during my Presidential visits to Branches) with majority opinion so far favouring a full exploration of the joint NZIC/RACI journal concept. However, there is also significant support for the option of desktop publishing and full investigation of this is also underway.

I know that the Institute and its Council will be in good hands for the forthcoming year. Please continue, and expand if possible, your support for the diverse and valuable activities carried out under the umbrella of the Institute.

Regards

Harry Percival  
President

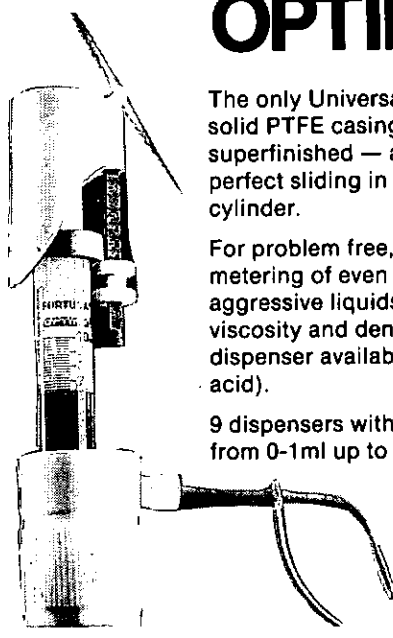

### FORTUNA<sup>®</sup> OPTIFIX<sup>®</sup>

The only Universal Dispenser with solid PTFE casing plunger, superfinished — a guarantee for perfect sliding in the precision glass cylinder.

For problem free, economical metering of even the most aggressive liquids with varying viscosity and density (special dispenser available for hydrofluoric acid).

9 dispensers within volume-range from 0-1ml up to 0-300ml.

*Available from*



**Labsupply Pierce (NZ) Limited**

Auckland: PO Box 34-234, Birkenhead  
Tel: (09) 443-5867 Fax: (09) 444-7314

Christchurch: PO Box 20035, Bishopdale  
Tel: (03) 358-7410 Fax: (03) 358-9598

For this special occasion I hope you will permit me to quote Professor Reiser of Texas A&M concerning my chapter on "Formation of Animal Fats" He was about to write an invited chapter for *Advances in Meat Research*<sup>5</sup>. His letter of 2/5/88 reads "I remembered your excellent paper in vol 3, *Progress in the Chemistry of Fats and Other Lipids*, Formation of Animal Fats.<sup>6</sup> It may be 33 years old but it is the backbone of its subject . . ." The generous outcome was to invite me to join him in the preparation of the chapter. His detailed knowledge of the significance of the serum cholesterol investigations and of CHD/saturated fat theory was a revelation to me. I was, however, encouraged to believe that I had contributed to the CHD/omega 3 aspects that had hitherto been neglected.

I had recently completed an invited chapter to *World Review of Nutrition and Dietetics* entitled "Is Our Knowledge of Human Nutrition Soundly Based?"<sup>7</sup>. This involved many different aspects, such as protein requirements, as well as fats. Aside from the usual requests for reprints and occasional encouraging comments I found that the main responses came from those immersed in the field. In particular, I recall a request from Dr Hugh Sinclair. In the letter he outlined his experiences with Eskimos with whom he had lived 40 years ago and agreed with my point concerning complete absence of non-infective Western diseases even though the diet lacked dietary fibre — a matter which he had explained to Burkitt and Trowell *ad nauseum* without success. Again I quote with some hesitation his comments about my review. "It is a magnificent contribution and raises a number of questions."

As described in a Lipid Group Colloquium<sup>8</sup> recently held in honour of Hugh Sinclair, on his 80th birthday, by 1937 he had in mind the relationship between the rise of Western diseases and essential fatty acid intake: indeed, one of his papers in support of the view became a citation classic, even though not making an impact earlier. It could not reasonably be expected that Sinclair's views would flourish in the absence of chemical knowledge of the polyunsaturated fatty acids and their eicosanoid metabolites. Similarly, I cannot expect the audience to appreciate the nutritive value of fats without first touching on their chemistry and biochemistry.

## Chemistry and Biochemistry of Fats and Other Lipids

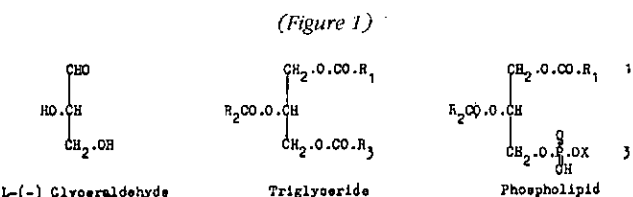

R<sub>1</sub>, R<sub>2</sub>, and R<sub>3</sub> represent alkyl groups corresponding to different fatty acids. X represents different substituent such as H (phosphatidic acid), ethanolamine, (phosphatidyl ethanolamine), choline (phosphatidyl) choline and inositol (phosphatidyl inositol).

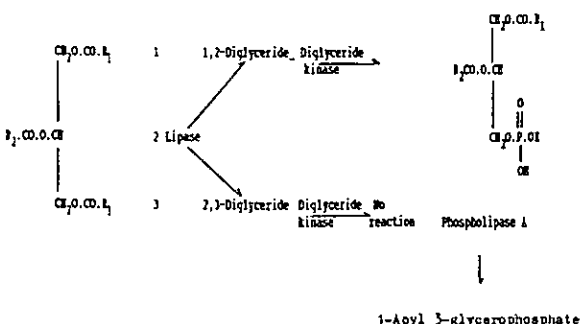

Figure 1. The structures and stereospecificity of triglycerides and of the phospholipides.

A lipid may be defined as a compound containing a fatty acid. Most of us are familiar with fats as the combination of three fatty acids with the trihydric alcohol, glycerol (Fig. 1). It may not be known, however, that the three carbons on the glycerol molecule are distinguishable. As shown, lipase yields a mixture of 1,2 and 2,3-diglycerides. Only the 1,2-diglycerides react with diglyceride

kinase to form, 1,2-diacylglycerophosphate, which is attacked specifically by phospholipase A to give 1-acyl glycerophosphate in which substituent X = H. All naturally occurring triglycerides relate back to L-(-) glyceraldehyde.

In another category of lipids (sphingolipids) the fatty acid is attached to the base sphingosine (Fig.2). Such lipids are associated with lipoproteins of blood and muscle and especially with neural tissues.

(Figure 2)

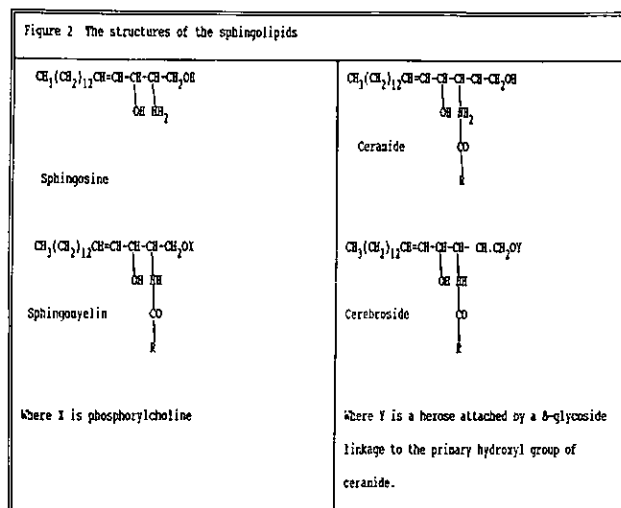

Other lipids include waxes or combinations of fatty acids with fatty alcohols. Such lipids are generally not major components of tissues; but, waxes of sperm whales, mainly, (oleyl oleate) and of *Simmonsia californica* (eicosenyl eicosenoate) are exceptions. It is common for alcoholic groups, such as those of cholesterol or vitamin A to combine with a fatty acid. Still other combinations involve the esterification of hydroxyl or amino groups of proteins giving rise to changes in their properties. Triglycerides (or fats) are typically the most abundant lipids. In animals used for meat production, fats may make up 60% of the body weight, as is the case with the obese human. Phospholipids, in contrast, tend to form a constant proportion of the fresh weight of a given tissue regardless of the plane of nutrition. For example, the amount in muscle tissue is about 1% of the fresh weight compared with about 3% in liver tissue.

(Figure 3)

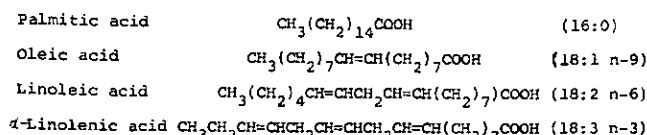

### n-6 or linoleic family

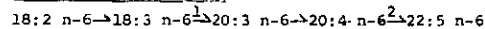

### n-3 or α-linolenic family

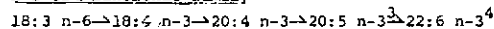

### Footnotes:

1. Gamma linolenic acid (GLA)
2. Arachidonic acid (AA)
3. Eicosapentaenoic acid (EPA)
3. Docosahexaenoic acid (DHA)

Figure 3. Structures and transformations of fatty acids

Fatty acids are conveniently described by their shorthand notations. The notation shows the chain length followed after the colon by the number of double bonds. The number after omega shows the position of the first double bond nearest to the omega or methyl end of the carbon chain. Two implicit assumptions are made: (a) The double bonds are arranged according to the usual methylene interrupted sequence and (b) the double bonds have a *cis* configuration. The omega 6 (linoleic acid) and the omega 3 (linolenic acid) families known collectively as polyunsaturated fatty acids (PUFA) are shown in Fig. 3.

Animals cannot synthesise polyunsaturated fatty acids *ab initio*. However, linoleic and linolenic (often written as  $\phi$ -linolenic acid) known as essential fatty acids, occur in the diet and are transformed in the tissues by desaturation and elongation into polyunsaturated C20 and C22 acids. In land animals linoleic acid often predominates giving rise to the omega 6 series of polyunsaturated C20 and C22 acids which are stored as phospholipids. Arachidonic acid (20:4 n-6) is perhaps the best known member. However, in aquatic animals, the food chain begins with the phytoplankton in which the lipids contain as major components the polyunsaturated C20 and C22 fatty acids derived very largely from  $\phi$ -linolenic (omega 3) acid. This pattern tends to pass unchanged both into the depot fats and phospholipids of aquatic animals, the main acids being eicosapentaenoic (20:5n-3) or EPA and docosahexaenoic (22:6n-3) or DHA. We are now in a position to study the fatty acid composition of animal and plant fats.

In the absence of dietary fats, animals produce endogenously from carbohydrates and proteins depot fats of simple composition comprising some 25% palmitic (16:0), 65% oleic (18:1n-9), 5% stearic (18:0) and lesser amounts of myristic (14:0) and palmitoleic (16:1n-7) acids. To these acids are added, as a rule, minor amounts of dietary fatty acids including linoleic and linolenic. In the case of the ruminant these polyunsaturated fatty acids are hydrogenated to stearic acid and oleic acid and its *cis* and *trans* isomers and conjugated isomers of linoleic acid. The composition of the fats of fishes is dictated mainly by that of the diet consisting of large amounts of C20 and C22 polyunsaturated fatty acids (PUFA) that characterise the fats of aquatic species.

The commonly available vegetable oils include the polyunsaturated seed oils rich in linoleic acid used for margarine and cooking oils. Examples include soybean, safflower and sunflower. In contrast olive (fruit coat) oil contains low levels of linoleic acid but is rich in oleic acid. Other examples of low linoleic oils include coconut, rich in lauric (12:0) acid, and palm oil, rich in palmitic and oleic acids. Data on the fatty acid composition provides also a much needed guide for the public wishing to make dietary decisions. The nutritional revolution now in progress required first an understanding of the nature of the chronic diseases affected by fats and second a certain minimum build up of biochemical and chemical knowledge of fats before it could take place.

## The Long Term Cause — Effect Time Gap (LTCEG)

In a simple situation the effect quickly follows the cause: if cyanide is swallowed death follows almost instantly. Thus the cause is quickly discerned albeit the mechanism involved may not be understood. Following the discovery of viruses and bacteria it is now possible to track down the cause of an infectious disease to a specific virus or bacterium. The time span between cause and effect is relatively short. With chronic diseases the time gap between the cause and the appearance of the effect may amount to several decades. For convenience I have designated this phenomenon LTCEG. A further complication is that whereas infectious diseases have a common cause, a satisfactory connecting thread in the causation of chronic diseases has not yet been found. Here we have an ill-defined cause operating on an ill-defined disease, coupled with LTCEG. There is already enough evidence, however, to implicate fats and especially their eicosanoid metabolites as being involved in chronic diseases. I will now attempt to take you briefly through the unravelling of the nature of fats as the critical step in the elucidation of their role in nutrition.

## A Short History of the Chemistry and Biochemistry of Fats

The study of natural products whether proteins, carbohydrates or fats generally requires that one must know first their chemical nature then follows the question of how they are synthesised in living tissues and finally their nutritional qualities.

M. E. Chevreul discovered the true nature of fats in 1814 as the glycerol of fatty acids and wrote a magnificent treatise in 1823. He died in Paris at the age of 103<sup>8</sup>. Apart from the observation of Lawes and Gilbert<sup>9</sup> that animals synthesise fat from dietary carbohydrate little progress was made until T. P. Hilditch F.R.S.

was appointed to the chair of Industrial Chemistry at Liverpool (1927-1956) to investigate oils, fats and waxes. This school ensured that more scientists were specifically trained in the area and important advances were made in our knowledge of the fatty acid composition and glyceride structure of natural fats. As a research student I was sceptical of the use of the theory of evolution advanced by Hilditch and Lovren<sup>10</sup> in 1936 as an explanation of the simplification of the fatty acid composition as one proceeds from the lower to the higher forms of animal life. For example, fish contain C14-C22 fatty acids, including polyunsaturated C20 and C22 acids whereas the fats of higher mammals were made up largely of palmitic and oleic acids. Accordingly, in 1952, I put forward the theory<sup>11</sup> that the simplification of fatty acid composition of animal fats depended on three factors: (1) composition of dietary fat, (2) formation of endogenous fat (mainly oleic, 65% and palmitic, 25% of total acids) and (3) ruminal hydrogenation. In fish factor (1) operates mainly. In amphibia, reptiles and most mammals factors (1) and (2) operate and in ruminants all three factors are involved.

My theory was supported by Deuel in 1955<sup>12</sup>. He discerned that Hilditch in commenting on my theory had mistakenly believed that horses and pigs were ruminants. To quote Deuel . . . "Although these examples are entirely correct they do not invalidate the Shorland hypothesis, since neither the pig nor the horse can be classified as a ruminant."

As reviewed by Longenecker<sup>13</sup> in 1944 fats were dispensable nutrients apart from the traces of linoleic acid which they contain. Burr and Burr<sup>14</sup> had shown in 1930 that linoleic acid was necessary for reproduction and prevention of skin permeability in rats, little realising that perversely the same acid would later be implicated as a factor in the causation of CHD. Progress in knowledge of the nutritional value of fats in the meanwhile remained static while their chemistry and biochemistry advanced.

As reviewed by the author<sup>6</sup> in 1955 adipose tissue was no longer seen as a static energy reserve. By isotopic labelling Schoenheimer revealed in 1946 a half life of fatty acids in rats of several days only. In 1951 Reiser reported that  $\phi$ -linolenic acid was converted to linoleic acid in the rumen, thereby establishing ruminal hydrogenation. Further investigations in 1955 by Shorland et al.<sup>15</sup> into this important discovery showed that in fact  $\phi$ -linolenic acid, the main fatty acid of pasture, was converted into stearic, oleic, *trans* and *cis* isomers thereof and traces of conjugated linoleic acid characteristic of ruminant fats.

Following the discovery in 1951 of active acetate as the thioester of coenzyme A by Lynen et al., details of fatty acid synthesis were embodied in the fatty acid cycle.<sup>16</sup>

Fatty acids of natural fats, hitherto believed to be made up of n-even numbered saturated and unsaturated fatty acids, were shown by Hansen and Shorland<sup>17</sup> in 1951 at the DSIR Fats Research Laboratory to contain also branched-chain fatty acids. There followed in 1954 the discovery by Hansen, Shorland and Cooke<sup>18</sup> of the presence in addition of n-odd numbered fatty acids. In the detailed studies which followed mainly on ruminants but also on fish (Morice and Shorland, 1952)<sup>19</sup> as well as plants the widespread occurrence of odd and even-numbered *iso* (C13-C19), (+)-*anteiso* (C13, C15, C17) acids and a multibranch C20 (phytanic) acid derived from chlorophyll, was shown. It is perhaps noteworthy that these discoveries preceded the advent of gas chromatography. We tested the above acids for their physiological effects but in general there was no evidence that their inclusion in natural fats at their normal levels of less than 5% of the total fatty acids was harmful. However, it was later shown by Shorland et al.<sup>20</sup> that phytanic fed at the level of 0.5g/day killed rats in 3 days but no effect was found at the level of 0.1g.

At this stage Reiser et al.<sup>21</sup> had elucidated the mechanism of absorption of fats and their reassembly in the lymph. The common origin of fats and phospholipids from 1,2-diacyl-sn-glycerol was established from the work of Kornberg and Pricer and of Weiss et al.<sup>3</sup> The origin of the C20 and C22 polyunsaturated acids (PUFA) from linoleic and  $\phi$ -linolenic acid by using patterns of the C20 and C22 ozonolysis products following the incorporation of acetate 1-C 14 was established by Klenk<sup>22</sup>. Perhaps the most important advance was made by Bergstrom who had begun his epic researches on the prostaglandins produced from the C20 and C22 PUFA as outlined in his (1983)

review.<sup>23</sup> We are now in a position to understand how fats became a central feature of nutrition in the last decade.

## Fats: The Centre of a Nutritional Revolution

An early event in this revolution was the recognition that  $\omega$ -linolenic acid had physiological properties that were entirely different from those of linoleic acid. In 1973, Fiennes et al.<sup>24</sup> found, for example, that the deficiency symptoms of the capuchin monkey were cured by replacement of linoleic with  $\omega$ -linolenic acid. Budowski obtained similar results with the chicken.<sup>25</sup>

In a 1982 review Tinoco reported that many fish require  $\omega$ -linolenic acid for normal growth, behaviour and reproduction<sup>26</sup> as do many insects for normal emergence. DHA (22:6n-3) is present in very high levels in the retina, cerebral cortex and sperm of mammalian species. In the retinal rods of rats, DHA forms 60% of the outer segments where there is a requirement for rapid polarisation and depolarisation in response to individual light impulses. Deficits of DHA in the photoreceptors decrease electrical transmission. In fact, Rhesus monkeys for normal vision have an absolute requirement for omega 3 fatty acids that is met by  $\omega$ -linolenic acid but not by linoleic acid.

Lamprey and Walker<sup>27</sup> showed that the reflexes and motor abilities of rats in which the levels of DHA in the whole brain have been reduced 80-90% compared with the controls developed normally. However, deficient rats exhibited fewer exploratory behaviours and performed poorly in a maze learning task.

The eicosanoids produced in tissues from their n-6 and n-3 PUFA in nanogram quantities in diversity of forms which may vary with the type of tissue. In Figure 4 arachidonic acid (20:4n-6) has been selected as an important precursor of prostaglandins and leukotrienes. In the discussion which follows it is important to understand that members of the omega 3 series such as  $\omega$ -linolenic acid strongly compete for the elongases and desaturases that transform linoleic acid into arachidonic acid as well as for the cyclooxygenases and lipoxygenases that transform arachidonic acid into eicosanoids. In their conversion to PUFA Holman in 1964 showed that  $\omega$ -linolenate has about a 10 fold greater affinity for the enzyme systems concerned than does linoleate.<sup>28</sup>

(Figure 4)

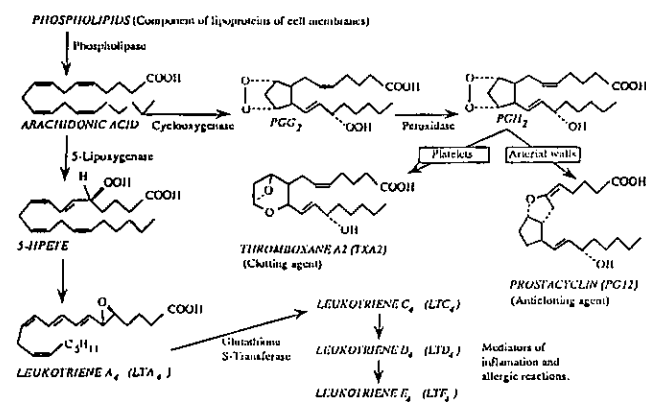

Figure 4. Biosynthesis of prostaglandins and leukotrienes from arachidonic acid with notes on their physiological properties. The transformation of PGG<sub>2</sub> to PGE<sub>2</sub> (vasodilator), PGF<sub>2a</sub> (vasoconstrictor) and PGD<sub>2</sub> (vasodilator) are not shown.

Many of the arachidonic (omega 6) eicosanoids as shown in Figure 4 have adverse effects such as elevation of blood pressure, platelet aggregation, inflammation and unfavourable immune response whereas the corresponding eicosanoids produced from eicosapentaenoic acid (omega 3) generally have the opposite effect. Thus excess eicosapentaenoic acid as in the Eskimo diet not only counters the harmful effects of arachidonic acid by preventing the formation of the clotting factor thromboxane A<sub>2</sub> (TXA<sub>2</sub>) but also forms non-clotting thromboxane A<sub>3</sub> (TXA<sub>3</sub>) consistent with the absence of CHD.<sup>29</sup> It will not be difficult to imagine that the effects of unfavourable eicosanoids may be accelerated by cofactor vitamins and trace elements. Thus Kearney, in a recent lecture at the University of Sydney, explained supplements such as Zn, pyridoxine, vitamin C and vitamin A all

augment the pathway of linoleic acid to arachidonic via delta 6 desaturase required for the production of unfavourable eicosanoids. Similarly the same supplements enhance the formation of favourable eicosanoids by facilitating the conversion of  $\omega$ -linolenic acid to eicosapentaenoic acid. Effective supplementation thus requires a favourable background situation. Some of the effects of eicosanoids are given briefly as follows:

## Coronary Heart Disease

As reviewed by Budowski<sup>30</sup> in 1988 the present epidemic of CHD is mainly due to an increase in the thrombotic properties of the blood, which accounts for a sevenfold increase in CHD deaths during the present century, without a substantial change in the extent or severity of atherosclerosis. Moncada and Vane<sup>29</sup> promoted the theory that CHD was mainly a thrombotic event determined by the ratio TXA<sub>2</sub> (clotting factor)/prostacyclin (anti-aggregatory factor) see figure 4. Reiser and Shorland in 1990 by putting all the biochemical evidence together defined CHD as a mainly thrombotic event that takes place against a hypercholesterolemic-atherosclerotic background.<sup>5</sup> It is caused by the conversion of arachidonic acid in the platelets to TXA<sub>2</sub>. According to Hyslop and York<sup>31</sup> the rate of conversion is enhanced by increasing levels of serum cholesterol. Further according to Sinzinger et al.<sup>32</sup> healthy arterial tissues generate anti-coagulatory prostacyclin nearly twice as rapidly as in atherosclerotic tissue.

Prevention of CHD is claimed through the inhibition of the cyclooxygenase reaction with such drugs as indomethacin and aspirin. However, Paganini-Hill et al.<sup>33</sup> found in 1989 that the risk of kidney cancer and ischaemic heart disease was increased significantly with daily aspirin users.

## Blood pressure

Many eicosanoids are vasoactive. Vasodilators which react synergistically with bradykinin and serotonin to increase vascular permeability include PGE<sub>1</sub>, PGE<sub>2</sub>, PGD<sub>2</sub> and PGI<sub>2</sub>. In contrast TXA<sub>2</sub> and PGF<sub>3</sub> are potent vasoconstrictors. Many trials have shown that blood pressure is reduced by dietary fish oils. Knapp and FitzGerald,<sup>34</sup> for example, found that the systolic and diastolic blood pressure of men with mild hypertension was significantly reduced with 50ml fish oil per day. A similar amount of safflower oil was ineffective as was 10ml fish oil. It is considered that the fall in blood pressure is not readily explained by changes in eicosanoid concentrations alone but that changes in membrane fluidity and increased erythrocyte deformability may also be involved.

## Bone Diseases

PGE<sub>2</sub> stimulates osteoclastic bone resorption by biosteoclasts in a number of pathological states. These may contribute to the destruction of bone in rheumatoid arthritis, osseous metastases and infections. Treatment of active rheumatoid arthritis with dietary fish oil supplements has indicated clinical benefits possibly owing to a decrease in inflammatory LTB<sub>4</sub> production<sup>35</sup>.

## Diabetes

In experimental diabetes in rats Storlien et al.<sup>37</sup> showed that high levels of linoleic-rich safflower oil produced insulin resistance in oxidative muscle and liver tissue.

This was completely prevented by substituting safflower oil with omega 3 rich tuna oil.<sup>38</sup>

## Cancer

Mammary tumours induced experimentally in rats by chemical agents are promoted by linoleic acid.<sup>39</sup> If the associated prostaglandin formation is prevented by indomethacin or by omega 3-rich fish oils the dietary effect of linoleic acid is abolished.<sup>40</sup>

Australia has the highest incidence of skin cancer in the world which Mackie<sup>41</sup> and Mackie et al.<sup>42</sup> suggest is related to the increased consumption of polyunsaturated vegetable oils. Skin cancers in hairless mice induced by ultraviolet irradiation are inhibited by indomethacin after irradiation. Indomethacin fed during irradiation was ineffective.<sup>43</sup>

Carcinogens transform normal cells into cancer cells and their future growth is dependent on the presence of potentiators, including endotoxins and the platelet aggregating factor (PAF), which have inflammatory properties. Similar properties are found

in the leukotrienes, LTC<sub>4</sub>, LTD<sub>4</sub> and LTE<sub>4</sub> (Figure 4) derived from arachidonic acid. In contrast leukotrienes derived from omega 3 eicosapentaenoic acid are anti-inflammatory and inhibit tumour growth.

### Parenteral Nutrition

At a recent symposium (ASPEN, 1988) the intravenous lipid emulsions currently available in the United States were considered.<sup>44</sup> They were made up of mixtures of soybean and safflower oil designed to produce non-glucose-nitrogen-sparing-calories and to provide essential (linoleic) fatty acid. However, the eicosanoids produced from their omega 6 precursor promoted clotting, inflammation and an unfavourable immune response. The fat emulsion should therefore be made up from medium chain fatty acids (C8-C12) as an immediate source of energy to spare the proteins in contrast to linoleic triglycerides which tend to remain in the fat depots. Omega 3 fish oil fatty acids which are anti-clotting, anti-inflammatory and enhance the immune system should also be included.

### Consequences of Unrestrained Arachidonic Acid Metabolism

Budowski<sup>45</sup> has drawn attention to the unfavourable effects of unrestrained arachidonic acid (AA) metabolism arising from the conversion of linoleic acid. It is known that increasing the levels of linoleic acid beyond the threshold value to alleviate deficiency symptoms is inappropriate and may in fact be disastrous through excess AA and eicosanoid production. Intravenous AA in rabbits causes platelet aggregation in lungs with fatal results and in rats intrajugular injection produces strokes.

As eicosanoid production is dose dependent it is likely that unless the levels of omega 6 are restrained by adequate levels of omega 3 fatty acids their adverse effects on health will persist. In Israel an omega 6/omega 3 ratio of 17 has been reached whereas in Britain a ratio of 10 was estimated which is probably typical of western countries. The evidence discussed by Budowski<sup>45</sup> indicated that the contemporary omega 6/omega 3 imbalance in western countries has occurred through the greatly increased surplus of edible linoleic-rich vegetable oils.

### Other Aspects of Fats in Nutrition

Many aspects have inevitably been omitted, for example, gamma linolenic acid (Figure 3) present in primrose oil is claimed to be effective in the treatment of myalgic encephalomyelitis and other ailments.<sup>46</sup> According to Bonanome and Grundy,<sup>47</sup> stearic acid, a major component of ruminant fats, though saturated is negatively cholesterolemic. Nevertheless the US Food and Drug Administration requires that stearic acid but not *trans* monounsaturated fatty acids (which raise serum cholesterol and LDL levels) be classified as saturated fatty acids.<sup>48</sup> If tested on the basis of a specific physiological response it becomes apparent that even in an homologous series of fatty acids each fatty acid may give a different response. Reiser et al.<sup>49</sup> found that cyclopropenoid acids, such as sterculic and malvalic acids, inhibit delta 6 desaturase resulting in high stearic acid and low oleic acid levels.

Occasionally, perceived physiological effects of fatty acids are incorrect as was the well known case of vaccenic acid in butterfat which was believed to enhance the nutritive value of butter. Similarly erucic acid (22:1n-9), characteristic of the seed oils of cruciferae was wrongly believed to cause myocardial (heart muscle) damage. Thus steps were taken to breed erucic acid free rapeseed oil for margarine manufacture.

It may be concluded that the nutritive value of fats and other lipids is very dependent on their fatty acid make-up and their positions on the glycerol molecule.

### Conclusions

Contemporary knowledge of the physiological properties of fatty acids and especially of the eicosanoid metabolites to which we are exposed daily, demands lipid literacy if we are to control their effects on chronic diseases. Lipid illiteracy is a major handicap to most organisations claiming to control and advise on health.

The meat and milk from our pasture-fed animals contain omega 3 polyunsaturated fatty acids derived from dietary  $\phi$ -linolenic acid, the main fatty acid of pasture. In contrast, corn-fed animals produced in many other countries in which dietary  $\phi$ -linolenic acid is absent are lacking in omega 3 fatty acid. Because

of lipid illiteracy, marketing authorities fail to make clear that our agricultural products are not only environmentally clean but they also contain omega 3 health promoting fatty acids.

### References

1. J. M. McGinnis and M. Nestle (1989). *American Journal of Clinical Nutrition*, 49: 23.
2. *Lancet* (1983). Editorial. *Lancet* i: 1193.
3. A. M. Pearson, Jane D. Lowe and E. B. Shorland. (1977). *Advances in Food Research*, 23: 1.
4. David P. Hamilton. (1990). *Science*, 250: 1331.
5. R. Reiser and E. B. Shorland. (1990). *Advances in Meat Research*, 6: 21.
6. E. B. Shorland. (1955). *Progress in Chemistry of Fats and Other Lipids* 3: 225.
7. E. B. Shorland. (1988). *World Review Nutrition and Dietetics* 57: 126.
8. Hugh M. Sinclair. (1990). *Biochemical Society Transactions*, 18: 756.
9. J. B. Lawes and J. H. Gilbert. (1866). *Philosophical Magazine*, London, 32: 4th series, 439.
10. T. P. Hilditch and J. A. Lovens. (1936). *Nature*, 137: 478.
11. E. B. Shorland (1952). *Nature*, 152: 924.
12. H. Deuel (1955). *Lipids*, 11: 522. Interscience Publishers, New York.
13. H. E. Longenecker (1941). *Journal American Dietetic Association*, 20: 83.
14. G. O. Burr and M. M. Burr (1930). *Journal of Biological Chemistry*, 86: 587.
15. E. B. Shorland, R. O. Weenink and A. T. Johns (1955). *Nature*, 175: 1129.
16. E. Lynce (1954). *Nature*, 174: 962.
17. R. P. Hansen and E. B. Shorland (1951). *Biochemical Journal*, 50: 207.
18. R. P. Hansen, E. B. Shorland and N. J. Cooke (1951). *Nature*, 174: 603.
19. E. M. Morice and E. B. Shorland (1952). *Chemistry and Industry*, 1267.
20. E. B. Shorland, Hansen R. P. and L. A. M. Prior (1966). 7th International Conference of Nutrition, 1(5).
21. R. Reiser, M. J. Bryson, M. J. Carr and K. A. Kuiken (1962). *Journal Biological Chemistry*, 236: 131.
22. E. Klenk (1954). *Naturwissenschaften*, 41: 65.
23. S. K. D. Bergstrom (1983). *Proceedings International Conference on Oils, Fats and Waxes*. Auckland, 105.
24. R. M. Fiennes, T. W. Sinclair and M. A. Crawford (1973). *Journal Medical Primatology*, 2: 155.
25. Budowski, C. M. Hawkey and M. A. Crawford (1980). *Annals Nutrition Alimentaire*, 34: 489.
26. J. Tinoco (1982). *Progress in Lipid Research*, 21: 1.
27. M. S. Lamptey and B. L. Walker (1976). *Journal of Nutrition*, 106: 86.
28. R. T. Holman (1964). *Federation Proceedings*, 23: 1062; 57: 214.
29. S. Moncada and J. R. Vane (1979). *Federation Proceedings*, 38: 66.
30. P. Budowski (1988a). *World Review Nutrition and Dietetics*, 57: 214.
31. P. A. Hyslop and D. A. York (1980). *Biochemical Biophysical Research Communications*, 92: 919.
32. H. Singlinger, W. Feigl and K. Silberbauer (1979). *Lancet* ii, 469.
33. A. Paganini-Hill, A. Chao, R. K. Ross and B. E. Henderson (1989). *British Medical Journal*, 299: 1247.
34. H. R. Knapp and G. A. FitzGerald (1989). *New England Journal of Medicine*, 320: 1037.
35. D. R. Robinson, S. Tateo, B. Patel and A. Hirai (1988). *Journal of Parenteral and Enteral Nutrition*, 12: No. 6 Supplement 37S.
36. J. M. Kremer, W. Jubiz (1987). *Annals of International Medicine*, 106: 497.
37. L. H. Storlien, D. E. James et al. (1986). *American Journal of Physiology*, 14: 576.
38. L. H. Storlien, E. W. Kragen et al. (1987). *Science*, 237: 885.
39. C. A. Carter, Shea, W. Millholl and M. M. Ip (1983). *Cancer Research*, 43: 3559.
40. I. M. Braden and K. K. Carroll (1986). *Lipids*, 21: 285.
41. B. S. Mackie (1974). *Medical Journal of Australia* 1: 810.
42. B. S. Mackie (1980). *Medical Journal of Australia* 1: 159.
43. M. Matheson, V. E. Reeve, C. Boehm-Wilcox and C. H. Gallagher (1988). *Proceedings of Nutrition Society of Australia*, 13: 90.
44. ASPEN (1988). *Journal of Parenteral and Enteral Nutrition*, 12: Supplement 35S-138S.
45. P. Budowski (1988b). *NATO Workshop on Dietary Omega 3 and Omega 6 Fatty Acids*. NATO-ASI Series A: Life Sciences (Eds C. Galli and Simipolous) pp97-110.
46. D. F. Horrobin (1989). Section A3 *International Conference on Fats*, Auckland.
47. A. Bonome and S. M. Grundy (1988). *New England Journal of Medicine*, 318: 1244.
48. S. M. Grundy (1990). *New England Journal of Medicine*, 323: 480.
49. R. Reiser, M. C. Williams, M. F. Sorrells and H. L. Murty (1963). *Archives Biochemistry Biophysics*, 102: 276.

## LOST, FOUND AND MOVED AROUND

Thanks to the note in this Journal of Dec. 1990, two of the missing war-time chemists have been found — Alex Lees is living in Upper Hutt, and building on the Kapiti Coast, and the Rev. Noel Bythell, who did go to Africa, now lives in Nelson.

However Lester Stonyer (our apologies for miss-spelling his name) is still keen to know about William Chappell, Ron Coventry, S. C. Denham, H. B. Oakley, John F. Martin, Earnest Sellens, Frank Thompson and a Mr Saxton.

Please bear in mind that many retired members of our Institute do NOT get this Journal — perhaps you could show them this paragraph and stir some memories!

Any scrap of information will be gratefully received by Lester, who has moved from Auckland to: 10 Manly Gardens Paraparaumu. Tel. (058) 73-123.

# New Zealand Institute of Chemistry/New Zealand Biochemical Society

# 60th JUBILEE CONFERENCE

26-28 August 1991, University of Canterbury, Christchurch

## Conference Speakers

### W. Clark Still

Professor Still is a Professor of Chemistry at Columbia University. His research interests are in the areas of natural products synthesis, new synthetic methods and molecular recognition. He is the author of two widely used molecular modelling packages: Model and Macromodel. The title of his address will be: *'Experimental Studies in Molecular Recognition — Selective Receptors of Peptides'*. Professor Still will also talk at the Modelling symposium with a title: *'Theoretical Studies of Molecular Recognition — Molecular Modelling of Stereoselective Complexation'*.

### Kim Janda

Professor Janda is an Associate Member in the Department of Molecular Biology and Chemistry, Research Institute of Scripps Clinic, La Jolla. He was one of the originators of the now well publicised field of catalytic antibodies. His research interests range from synthetic organic chemistry to enzymology and molecular biology. The title of his talk will be *'Catalytic Antibodies: Fundamental Insights on Abzymes in Acyl Transfer Reactions'*.



### Frank P. Larkins

Professor Larkins is Deputy Vice-Chancellor (Research) and Professor of Chemistry at the University of Melbourne. From 1983-90 he was Professor of Chemistry at the University of Tasmania. He was President of the Federation of Australian Scientific and Technological Societies during 1988-89. This organisation has been responsible for raising the profile of the importance of science and technology in Australia. He is currently Vice-President of the Royal Australian Chemical Institute. His research interests are in the fields of theoretical chemical physics, synthetic liquid fuels from coal and natural gas, and science and technology policy. The title of his address will be: *'Science and Technology Policies in Australia: Planning for the Future'*.



### Sir Richard Norman

Sir Richard is Rector of Exeter College, Oxford and Scientific Adviser, Department of Energy, U.K. He was Chief Scientific Adviser, Ministry of Defence, U.K. from 1983 to 1988. He was President of the Royal Society of Chemistry from 1984-1986, whom he will represent at this Jubilee Conference. From 1965 to 1983 he was



Professor of Chemistry at the University of York. Sir Richard will be the speaker at the Conference Dinner to be held in Cloisters Restaurant. He will also contribute to the Chemical Outreach series of lectures to High School teachers and students.

### Robert Ramage

Professor Ramage is Forbes Professor of Organic Chemistry and Head of the Department of Chemistry, University of Edinburgh. Prior to moving to Edinburgh in 1984 he was Professor of Organic chemistry at UMIST. From 1961 to 1964 he participated in the total synthesis of vitamin B<sub>12</sub> and cephalosporin C with R. B. Woodward. His research interests are in the biosynthesis and synthesis of natural products. He is President of the Perkin Division of the Royal Society of Chemistry. He will be an Erskine Fellow in the Department of Chemistry, University of Canterbury. The title of his talk will be *'The Chemical Synthesis of a Protein'*.



### Easterfield Medal

The 1990 Easterfield Medallist, Dr Vickie McKee, University of Canterbury will present an address on her research, entitled *'Multimetal Macrocycles'*.

### Australian RSC Lecture

Professor David St C. Black, Professor of Organic Chemistry and Head of the School of Chemistry at the University of New South Wales, will deliver his 1990 Australian RSC lecture entitled *'New Dimensions in Indole Chemistry'*.

### Watson Victor Award

The 1991 Watson Victor Award winner will also address the conference.

### Conference Symposia

The conference will be organised in a series of symposia. There will also be an opportunity for all those wishing to present an Oral or a Poster Paper on any area of Chemistry or Biochemistry. Abstracts should be sent immediately to the Conference Secretary.

#### 1. History of the N.Z.I.C.

Chairperson: Denis J. Hogan  
Keynote Speaker: Ian D. Rae, Monash University  
A panel including Denis Hogan, Stan Winter and John Pollard will discuss the history of the N.Z.I.C.

#### 2. Synthesis

Chairperson: Brian R. Davis, University of Auckland  
Keynote Speaker: Yoshinori Yamamoto, Sendai University  
The symposium will also contain contributions from Masaki Hasegawa,

Tokyo; Margaret Brimble, Massey; Ivan Lantos, Smith Kline Beecham, U.S.A.; David Larsen, Otago; and Richard Neidlein, Heidelberg.

#### 3. Natural Products

Chairperson: Graeme B. Russell, Biotechnology Division, DSIR  
Keynote Speaker: Jack Elix, A.N.U.  
Other speakers will include Stephen Bloor, DSIR; Robin Mitchell, DSIR; Nigel Perry, MAF Tech; and Daryl Rowan, DSIR.

#### 4. Reaction Mechanisms

Chairperson: Michael P. Hartshorn, University of Canterbury  
Keynote Speaker: Athol L. J. Beckwith, A.N.U., Canberra  
The symposium will cover the topic from both an inorganic and an organic perspective. Other speakers will include David Buckingham, Otago; Brian Halton, Victoria; Don House, Canterbury; Laurie Main, Waikato; and Charmain O'Connor, Auckland.

#### 5. Spectroscopy

Chairperson: Leon F. Phillips, University of Canterbury  
Keynote Speaker: G. Michael Bancroft, University of Western Ontario  
Major contributions will be made by Mike Chesters, University of East Anglia and Robert F. Curl, Rice University.

#### 6. Modelling

Chairperson: James M. Coxon, University of Canterbury  
Principal Keynote Speaker: W. Clark Still, Columbia University  
The symposium will feature some of the international leaders in this field. Invited speakers include Frank Blaney, Smith Kline Beecham UK; Dennis Gerson, IBM USA; Peter Gund, Merck, Sharp and Dohme Research Laboratories, USA; Geoff A. Lane, DSIR; Gerald M. Maggiora, Upjohn Company, USA; Craig Marshall, Cambridge University; D. Quentin McDonald, Canterbury; Eiji Osawa, Toyohashi University of Technology; David Parry, Massey; and James F. Snyder, G. D. Searle Research and Development, USA.

#### 7. Environmental/Analytical.

Chairperson: Keith A. Hunter, University of Otago  
Contributions on a diverse range of topics in environmental/analytical chemistry are expected.

#### 8. Industrial Chemistry

Chairperson: A. John McKinnon, W.R.O.N.Z.  
Contributions from chemists in New Zealand industries are actively being sought for this symposium.

### 9. Primary Produce Chemistry/ Chemistry of Food and Drink

Chairperson: Graeme M. Keeley, Canterbury Frozen Meat

This symposium will include a panel discussion titled 'The changing role of research in primary produce, food and drink in the 1990s'. Speakers will include leaders of research organisations in these fields.

### 10. Inorganic

Chairperson: Derek W. Smith, University of Waikato

Keynote Speaker: Edward I. Solomon, Stanford University

Contributions from several younger New Zealand organic chemists will be included.

### 11. Biochemical Toxicology

Chairperson: Christine C. Winterbourn, Christchurch Hospital

Mechanism of action of anticancer drugs, toxicity of environmental chemicals and biological defence mechanisms will be discussed. Speakers will include Bruce Baguley, Auckland Cancer Research Laboratory; Bill Wilson, Auckland Medical School; Rex Munday, Ruakura; and Alan Clark, Victoria University of Wellington

### 12. The Forensic Chemist

Chairperson: Ross Boswell, Christchurch Clinical School

A panel of speakers will address this topic from the perspective of the chemical, legal and medical professions.

### 13. Molecular Medicine

Chairperson: Steve Brennan, Christchurch Hospital

Keynote Speaker: Wendy Jessup, Heart Research, Sydney

### 14. Biochemistry

Chairperson: Maurice Barnes, Lincoln University

This symposium will include a wide range of biochemical topics.

### Molecular Modelling Workshop

A workshop on molecular modelling, organised by Jim Coxon, University of Canterbury will be held on Thursday, 29 August, 1991. Jim P. Snyder who is Senior Fellow and Head of Drug Design at G. D. Searle, Research and Development, Illinois will be the chief instructor. Dennis Gerson of IBM USA will also be in attendance.

### Outreach Programme

On Wednesday, 28 August, 1991 a special programme for high school teachers and students will be held. Four conference delegates will give short lectures on recent advances in Chemistry. The talks will be:

Sir Richard Norman, Exeter College, Oxford. 'Scientific Policy Related to Energy (U.K.)'

Dr Peter Gund, Merck, Sharp and Dohme Research Laboratories, New Jersey.

'Computer Aided Discovery of New Medicines'

Professor Michael Bancroft, University of Western Ontario.

'The Excitement of Scientific Research'

Professor Robert Curl, Rice University, Houston.

'CGO: Yesterday and Today'

A session for High School teachers will be held on the Wednesday afternoon.

Further details may be obtained from the Conference Secretary: Dr R.G.A.R. Maclagan, Department of Chemistry, University of Canterbury, Christchurch (Phone 64-3-642-456; Fax 64-3-642-110; e-mail CHEM171@CSC.CANTERBURY.AC.NZ).

# ANNUAL REPORT FOR 1990/91

## Finances

It is pleasing to report that the financial situation which looked quite difficult early in the financial year was able to be stabilised by closer control over expenditure (without jeopardising the current range of Institute activities) and improvements in income other than from subscriptions. One successful innovation to reduce costs was the decision to hold a telephone conference for one of the two full Council meetings (viz February 1991 Council). Council, in February 1991, was able to resolve that subscriptions for the 1991/92 financial year would remain at 1990/91 levels.

The Annual Accounts for 1990/91 show that income exceeded expenditure by about \$18,000, which will help the Institute's previously depleted reserves, but it is unlikely that this situation will be expected next year, unless there is significant increase in membership. A breakdown of expenditure for this reporting period is shown in the accompanying chart.

NZIC Expenditure for 1990/91 was as follows		
	\$	%
Education, Prizes	5,000	3.9
Publications	41,500	32.0
Branch Grants	12,000	9.3
Travel/Accom.	7,000	5.4
Affiliation Fees	1,000	0.8
Salaries	37,000	28.5
Admin. Expenses	14,000	10.8
Rent, Establish. Costs	5,000	3.9
IPENZ Admin Fees	4,000	3.1
Auditors	3,000	2.3
	129,500	100.0

## Rule Changes

During this year several rules of the Institute were changed so as to delete the requirement for a quorum at an Annual General Meeting and to introduce a small subscription (in addition to paying for the Journal) for Life Members elected after August 1990. In addition to these rule changes (published in the Journal) an editorial update of all the rules has been carried out and will be circulated to members along with an updated List of Members later this year.

## Membership

As shown by the accompanying changes in membership numbers over the last two years, resignations have outnumbered new membership. This is obviously of concern to Council and pressure for the promotion of recruitment remains. An analysis of recent resignations showed that they fall into four main categories

- overseas and have lost association with New Zealand
- no longer associated with chemistry in any form (this was by far the most numerous category)
- ill-health, and
- subscription level too high.

	HonFNZIC	FNZIC	MNZIC	ANZIC	Stud.	Local	Total
1991	38	323	794	170	148	11	1,484
1990	40	330	820	180	155	12	1,537

The apparent general movement out of New Zealand Chemistry is of concern and may reflect the recent and current disruption of science structures in New Zealand and the documented fall in industrial research and development expenditure. One disappointment this year also was that the amalgamation, several years ago, of previous non-corporate grades (Technicians, Graduates and Associate) into one Associate grade has still not borne fruit in substantially larger numbers of Associate members.

To help widen membership of the Institution the concepts of affiliate and corporate membership were raised at Council by the Canterbury Branch. An affiliate grade would replace "local member" and for other grades, and would be a non-corporate grade for those interested in chemistry but ineligible for other grades, and corporate grade would cover organisations interested in chemistry. Canterbury Branch were asked to develop further the definitions of these proposed grades for future consideration by Branches and Council.

## Prizes and Awards

For the reporting period, the following prizes and awards were made

- EASTERFIELD AWARD:  
Dr V. McKee (Canterbury University)
- ICI PRIZE:  
Dr K.J.D. Mackenzie (DSIR Chemistry, Lower Hutt)

- SHELL PRIZE FOR INDUSTRIAL CHEMISTRY:  
Dr I.W.M. Brown, Dr K.J.D. Mackenzie, and Mr G. V. White  
(DSIR Chemistry, Lower Hutt)
- CHEMICAL EDUCATION PRIZE:  
Mr R. Jansen (Middleton Grange School, Christchurch)

The AC Kennett Award went to an Australian (Mr A. Kairaitis) this year. The NZIC/RACI Visiting Speaker for 1990 was Dr R. Furneaux, DSIR, Lower Hutt.

Three Honorary Fellows of the Institute were elected this year —

Mr T. R. Hitchings (Canterbury)  
Professor M. F. Robinson (Otago)  
and Dr A. J. Ellis (Wellington).

Council's congratulations go to all those named above.

The Annual CHEM 13 examination was held during October 1990. Over 1300 Form 6 and 7 students participated from 104 Secondary Schools. The winner was James McDonald, Form 6, Mt Albert Grammar School.

### Chemical Olympiad

Council decided that involvement in the Chemical Olympiad event should be explored this year. New Zealand has been participating in the Mathematics Olympiad but has not yet entered the Chemical Olympiad. Council approved Dr R. MacLagan as the official New Zealand observer to the 1991 event in Warsaw, Poland in July, with a view to sending a team to the USA in 1992. Substantial sponsorship will be required to provide the necessary resources for training and sending a team.

### Council Committees

During this year membership and roles of all Council Committees were reviewed. In particular, the following Committees were re-constituted and are now based at different host Branches (in order to rotate the Council's discharge of responsibilities from time to time). The Chemical Education Committee is now based in Auckland (convenor Professor John Packer) and has begun work on linking schools to chemistry based organisations for education purposes. The Environmental Committee is also based in Auckland (convenor Mr Norman Thom) and is an amalgamation of the previous Environment and Hazardous Chemical Committees. The Public Affairs and Science Policy Committee is based in Wellington (convenor Mr Walter Freitag) and has already contributed two submissions to the Task Force on the establishment of Crown Research Institutes and one submission on the criteria and priorities of the Lottery Science Research Distribution Committee, amongst other work.

### Specialist Groups

Specialist Groups received particular attention from Council this year, with the President continuing the liaison role between the Council and the Groups that was started last year. Auckland Branch presented a submission to Council on the relationships between Council and Specialist Groups and this was subsequently revised into a set of suggested operational guidelines by Dr Penny Brothers, Auckland Branch in consultation with the President. This discussion paper was to be circulated to Specialist Groups and Branches for comment. Activities of, and information about, the Specialist Groups this year were generally well-covered in the article on Specialist Groups in the August 1990 issue of "Chemistry in New Zealand".

### NZ Chemical Industry Council

The Institute has in recent times become a member of the NZ Chemical Industry Council (formed in 1985) as an Associate Member (for which we now pay a subscription fee). This is a particularly useful relationship with the chemicals industry since they have their own committees on Safety and Health, and Environmental Protection with which our own Environmental Committee can liaise.

### NZ Conferences

In August 1990 the Annual NZIC Conference was held in Wellington, co-hosted by the NZ Biochemical Society and the NZ Plant Physiologists Society. With its wide range of good quality overseas and NZ plenary speakers and some very good symposia, this was a successful Conference in terms of attendance, presented papers, and financial return to the Institute. At the end of this reporting period the arrangements for the 1991 Annual Conference (60th Anniversary Conference) to be held in Christchurch were well in hand. The 1991 Conference Chairman,

Dr Jim Coxon, was co-opted to Council until this Conference takes place (this co-opting mechanism will now take place for all future Annual Conferences to help Council in its oversight role).

In February 1991 a very successful NZIC/RACI Inorganic Conference (IC'91) was held at Waikato University involving our own Inorganic and Organometallic Chemistry Specialist Group and their Australian counterparts, continuing what is a very fruitful collaborative link between the two Institutes. IC'91 attracted 250 attendees over the five days of the Conference.

At the end of this reporting period it appeared that the 1992 Annual NZIC Conference would not go ahead, since no Branch was in a position to host it (until 1993 when Auckland will be the host). Alternatives, such as encouraging NZIC members to attend the Ninth National Convention of the RACI in 1992 and approaching NZIC Specialist Groups to suggest that they consider holding their own Conferences in 1992 were being explored.

### PACIFICHEM 1995

An invitation to the Institute to co-sponsor the 1995 International Chemical Congress of Pacific Basin Societies (PACIFICHEM) along with the Chemical Societies of the USA, Canada, and Japan (and now also Australia) was received late in the reporting year.

Co-sponsorship will be formally accepted in the near future and Dr Brian Halton, who has been our representative on PACIFICHEM matters, will be the Institute's official representation on the 1995 PACIFICHEM organising committee.

### RSC 150th Anniversary

Professor John Packer, Auckland, attended the 150th Anniversary Congress of the Royal Society of Chemistry (RSC) in London in April 1991. While there he presented an "illuminated" scroll of congratulations and best wishes from the Institute to the RSC President, Sir Rex Richards.

### NZIC/RACI Cooperative Agreement

At the August 1990 Council Meeting, Dr David James, then RACI President, introduced for consideration a Memorandum of Understanding between NZIC and RACI on the formation of an Association of Chemists in Australia and New Zealand (ACANZ) with the prime aim of furthering joint cooperation activities on a more formal basis. This Memorandum of Understanding was subsequently signed by the then NZIC President, Dr Joyce Waters, and Dr James at the closing ceremony of the 1990 Annual Conference in Wellington on 23 August 1990.

### NZIC Journal

The publishing of the NZIC Journal "Chemistry in New Zealand" has been under review this year, particularly since the ACANZ Memorandum of Understanding (see previous paragraph) specified the establishment of a joint Journal to replace "Chemistry in New Zealand" and "Chemistry in Australia". At the end of the reporting period the joint journal concept had not been finalised because the anticipated costs, at that stage, far exceeded the current costs of the NZIC Journal (mainly caused by the fact that the RACI Journal has 12 issues per year as against 6 for the NZIC Journal). Dialogue is continuing with the RACI on the joint Journal, but desktop publishing in New Zealand is another possible option being investigated.

At the beginning of 1991 the first issue of the Journal for the year was held up by lack of material and soon after its eventual release the Institute was forced to change publisher to Michael Pervan Holdings Ltd. Council appreciates the rapid response to our publishing problem by both the new publisher and the Editor, Mr Ron Hall.

### Other NZIC Publications

Council was, this year, very pleased to support financially the continuance of CHEM NZ (targeted at secondary school teachers). This is an excellent publication on behalf of the Institute in its educational role and is now edited by Denis Hogan for the Chemical Education Specialist Group based in Christchurch.

At the end of the reporting period, it has been resolved by council that the "Careers in Chemistry" publication should be updated sometime in 1991. Waikato Branch agreed to coordinate the revision and production and sponsorship to help defray costs was to be sought from the NZ Chemical Industry Council and Chemistry Departments in the Universities.

H. J. Percival  
President

# PUBLIC AFFAIRS SUBMISSIONS & REPORTS

## *SUBMISSION OF THE POLICY AND PUBLIC AFFAIRS COMMITTEE ON THE INTERIM REPORT OF THE TASK FORCE ON ESTABLISHING CROWN RESEARCH INSTITUTES*

Your Policy and Public Affairs Committee has made the following submissions to the Task Force, following discussions with individual members, member groups and other interested groups.

Such discussions have had to be held within the short time available which has permitted only limited circulation of the draft proposals; the Task Force's final report will doubtlessly offer further opportunity to comment.

Our comments aim to offer positive, practical contributions (the decision to form CRIs has already been committed and their main groupings recently announced) representing an overall view of our profession, rather than focussing on specific sectors.

Whilst our views may differ from some of those expressed by individuals or sector groups, we have taken pains to ensure no significant conflicts within NZIC and hope that we have achieved that aim.

We invite members to contact us regarding any views they would wish our Institute to express.

## ESTABLISHMENT OF CROWN RESEARCH INSTITUTES SCIENCE TASK GROUP'S INTERIM REPORT

I. New Zealand Institute of Chemistry supports the establishment of Crown Research Institutes and urges that the processes of planning and establishment focus on two fundamental principles —

### THE OVER-RIDING NEED TO:

1. Stimulate, maintain and develop scientific and technological activities necessary to ensure New Zealand's progressive social and economic welfare;
2. Provide and apply New Zealand's scientific and technological resources (skills and equipment) to the maximum efficiency and cost-effectiveness to the nation (and the users of specific services).

II. To achieve these objectives, New Zealand Institute of Chemistry urges positive provisions for the following components as pre-requisites to establish of CRIs — to be defined in the Task Group's final recommendations.

The components are listed below and brief supporting notes for each are attached.

### IN SETTING UP CROWN RESEARCH INSTITUTES, GOVERNMENT SHOULD:

1. Establish a balanced, integrated grouping of CRIs
2. Substantially preserve the major discipline of chemistry and its resources within one appropriate CRI
3. Provide positive career structures with attractive opportunities for progression
4. Promote effective collaboration between teams working in different CRIs and other science institutions

5. Establish a national information centre (library, computer network) for common use by all CRIs and other science institutions
6. Ensure that competent scientific and technological knowledge and experience are represented on CRI boards of directors
7. Maintain and develop individual scientific disciplines; promote relevant fields of specialisation
8. Define and provide for total costs of establishing CRIs
9. Prescribe realistic, competitive pricing structures for CRI services
10. Maintain adequate funding of research vital to New Zealand's long term welfare and development.

### NOTES

1. We support the direction of opinion to date; CRIs dedicated to the following fields would best serve overall needs:

Animals	: (Agriculture, pastoral)
Plants	: (Horticulture, crops)
Forestry	: (Forests, timber, wood products)
Industrial	: (Materials, processing)
Geosphere	: (Earth)
Biosphere	: (Land, water, atmosphere)
People	: (Social, health, justice)
Support	: (Infra-structure, natural sciences, information, major facilities)

2. We endorse our original submissions to this proposal, specifically to avoid fragmentation and duplication of high-cost national resources. A major part of the discipline of Chemistry

could effectively operate within a CRI dedicated to industrial processing to rationalise existing resources in the DSIR Chemistry Division. Alternatively, Chemistry could be preserved within a supporting CRI, incorporated with other physical sciences.

We express concern over possibilities of separating — perhaps ultimately selling off — essential analytical services which play an important role in health and forensic sciences and use the same skills and equipment as other work in Chemistry.

3. The fragmented management structure of science under the CRI proposals, combined with the short-term nature of most CRI funding, will inhibit the development of satisfactory career structures for scientists. This will dissuade yet more students from choosing careers in science — in turn reducing further the numbers of scientists and technologists necessary to maintain essential scientific programmes, especially in face of growing international competition for qualified and experienced people.
4. The development of 'corporate' image and character is likely to inhibit collaboration between scientists working in separate CRIs, to the detriment of New Zealand science.

Positive steps must be taken to promote fruitful collaboration; for example, by requiring shared uses of major equipment, facilitating joint programmes, exchanges of staff, exchange of scientific information.

5. The issue of infrastructure, such as library, computer and major equipment of common interest and uses will need to be effectively dealt with on a national basis, not just by reorganising existing assets of merging departments. Such facilities have high capital and operating costs which must be productively utilised; the country cannot afford further costly fragmentation and duplication of such facilities.
6. The effectiveness of each CRI will critically depend upon the appointments to its controlling Board of Directors. Specific provisions must be made to ensure good understanding of the relevant sciences and technologies and research process, to complement management and financial skills. Such policy has been strikingly demonstrated in the world's leading economics and enterprises.
7. The change in focus from discipline to sector orientation leaves maintenance of disciplines to the universities

which are coming under increasing financial constraints and the scientific societies which lack the necessary resources.

The Royal Society and its affiliated societies are well placed to fulfil this role and must be given adequate resources as well as practical support from individual CRIs.

8. The total costs of restructuring have not been identified, but must be large, with few short-term savings apparent. Restructuring costs cannot be borne by the science vote allocated to pursue scientific work and related services. The source(s) of restructuring costs must be found and identified if government's objectives in setting up CRIs are to be realised and the infant CRIs to be financially nurtured.
9. If CRIs are to fulfil their proposed objectives, the prices charged for their services must be realistic and competitive. Appropriate criteria should be defined from the outset.
10. Whilst we appreciate that mechanisms for funding are questions separate from the principles of establishing CRIs, we nevertheless would like to see clearer provisions for ensuring adequate on-going funding for long-term research projects necessary to the nation's interests (eg disease prevention, climatic changes) rather than the shorter term benefits to specific sectors or users, for uncommitted work as/when necessary and for major capital items beyond the capacity of any single CRI.

Doubtlessly, individual CRIs, once established, will themselves take active and responsible steps to ensure that these important requirements are met; they will require adequate support and guidance. To this end, we request that frameworks and essential criteria for the requirements we have listed, be clearly defined and embodied in the legislation establishing CRIs or regulations covering their operations.

We take this opportunity to commend the Task Group on its full and prompt report on such a major topic and record our appreciation of the opportunities for consultation.

Professor N. F. Curtis; Dr G. J. Leary; Mr W. Freitag (Convenor)

SCIENCE POLICY AND PUBLIC AFFAIRS  
COMMITTEE NEW ZEALAND INSTITUTE  
OF CHEMISTRY (INC)

## SUBMISSION ON SCIENCE EDUCATION

Dear Dr Lockwood Smith,

The Science Policy & Public Affairs Committee of the New Zealand Institute of Chemistry expresses appreciation of your announcement to increase emphasis

on science and technology and to establish standards of achievement in the secondary school system. Your timely initiative is warmly commended.

Our Institute is the professional body representing a large segment of the scientific community and has become increasingly disturbed over declining standards in science and mathematics and the declining proportions of students taking scientific and technical subjects.

We confidently expect the changes you have announced to reverse these trends, which we consider essential for the revival of the New Zealand economy.

Doubtlessly, your Ministry will have advised you of the practical requirements to make your scheme successful and we take this opportunity to reinforce the essential needs for:

1. competent, fully trained and well motivated teachers.
2. on-going in-service training
3. effective science syllabi
4. teaching resources, especially facilities for practical work
5. more positive perceptions of and attitudes to science, among teachers, administrators and the public

You will doubtlessly recognise the need to address deficiencies in these areas and we offer the following comments:

1. There are currently inadequate numbers of teachers trained and competent to teach science subjects, particularly chemistry, physics and mathematics; far too many of such classes are being 'taught' by people with little or no background in the physical sciences.

Any increase in student numbers which your scheme generates will inevitably exacerbate this problem.

In the long term, recruitment and training of suitable teachers will be necessary, but in the meantime a massive campaign must be mounted to provide in-service training for present teachers who are weak in physical sciences.

2. In-service training must be provided on an on-going basis. Provisions for such training are currently at the discretion of Boards of Trustees and more positive emphasis and support for sciences must be provided, through specifically targeted resources.
3. Syllabus development in science has been inadequate for many years, as indicated by the difficulties encountered with the recently proposed Form I-IV science syllabus.

This attempted to make science more relevant in the junior and middle schools, to encourage pupils to continue with science subjects. Requiring poorly motivated students to study science in the fifth form only detracts further from your aims to encourage the sciences, so effort must be directed to develop and trial the revised syllabi. Successful teaching of such revised syllabi rests heavily upon wide and effective in-service training, as noted in (2).

4. Together with in-service training and syllabus development, a commensurate increase in provision of resource materials for science teachers is necessary. The development of such critical material appears to have been one of the casualties of recent educational 'reforms'.

If science teaching is to be successful in changing public attitudes, it must be seen to have practical connections, as traditionally taught 'hands on' in the laboratory. This aspect of science teaching is vital to instil enthusiasm, understanding and competence; sadly, the amount of such practical science experienced by many pupils has become quite inadequate, through the combined effects of poorly trained teachers, poor motivations, negative attitudes to science — and lack of adequate laboratory facilities; either none or grossly sparse or overcrowded. Positive provisions must be made, for organising and operating school laboratories to achieve the desired objectives. Appropriate incentives for establishing more effective schools-industry links would also be helpful in improving practical perceptions of science and contributing relevant resources.

5. Many of the problems with science training originate in the negative public perceptions of science, reinforced by poor experiences of science in the primary schools. Far too many teachers communicate such negative attitudes to their pupils. Such attitudes originate in poor learning experiences in science; we suggest that you require the training of all primary teachers to contain sufficient science to ensure that they can properly teach the primary science syllabus and thus foster enthusiasm to pursue science subjects successfully through higher levels. A major campaign is needed to strengthen understanding and appreciation of science in our teachers, to ensure that all pupils have a sound, positive introduction to science concepts, enabling each to advance to their individual aspirations and capacity.

Our Institute also supports your suggestions to place more emphasis on technology in schools

We are concerned however, over current trends to divorce technology from science; modern technology is essentially derived from science and engineering and its removal from these bases leaves little more than craft skills.

The development of such craft skills is positive and desirable but contributes little to the types of technology now necessary to revitalise the New Zealand economy. Accordingly, we would wish to see your programmes concentrate on science-based technologies, rather than on practical crafts in isolation.

In conclusion, we re-affirm our support for your proposed changes and are confident that you fully understand the needs for resources necessary to achieve

improvements in science and technology training essential to our national development; our comments aim to support you in your quest for such resources.

We do stress the need for prompt actions.

Discussions about improving science education seem to be perennial and time is overdue to stem the flow of pupils through the education system who emerge with poor understanding of science and lack of appreciation of the importance of technological development to the future well-being of New Zealand.

We take the liberty of copying these proposals to your colleague, the Minister for Science & Technology, to facilitate fruitful discussion at the interfaces of your respective portfolios.

With best wishes in your endeavours,  
Yours sincerely,

Professor N. F. Curtis  
Dr J. G. Leary  
W. Freitag (Convenor)  
SCIENCE POLICY & PUBLIC AFFAIRS  
COMMITTEE NEW ZEALAND INSTITUTE  
OF CHEMISTRY (INC)

## AUCKLAND BRANCH NEWSLETTER — JUNE 1991

From the Chair:  
One of the more significant events in the Branch calendar is the President's visit.

This presents one of the few opportunities members have, to find out what is happening at "Head Office" with respect to Institute affairs. There are several contentious issues facing us at present, especially the future direction of the Journal in the light of closer ties with RACI. At the meeting on June 11th, Dr Harry Percival provided an enlightening, if slightly depressing view of the merged journal proposal, however your Branch Committee is strongly of the view that such a merger is essential to the Institute. We will let you know when news is forthcoming from council.

The "History and Chemistry" talk was fascinating and very well supported. Our thanks to Richard Sorrenson the speaker, and to John Packer for his help in putting the meeting together. There is some interest in a field trip later in the year to the Morrinsville peroxide plant, so we will see what can be arranged. I would like to express our thanks, on behalf of the Branch, to Jennifer Butcher who is overseas for the rest of the year, for her time on the Branch committee. Her expertise in understanding the concerns of the science education community will be missed. Her work in the promotion of the views of Science Teachers will be continued by Ian Torrie, who we have asked to join the Committee for the remainder of the Year.

Jim Metson

## CONGRATULATIONS

We are pleased to note that Dr John Rogers has been made a Fellow of the Royal New Zealand Institute of Horticul-

ture for his work in Fertilizer Research. This is a rather rare honour for a chemist and we would like to take the opportunity to offer Dr Rogers our congratulations.

## WAIKATO BRANCH NEWS

The Waikato Branch programme began in convivial style on 30 April 1991 with a Barbeque held at the University Common Room Club, to which members and students were invited. Regrettably the weather was unseasonably wet and cold with predictable consequences on the numbers attending. Nonetheless for the 30 who came along the event was a great success, enhanced by a thoroughly interesting and entertaining address by Dr Pat Holland of Ruakura Research Centre. His talk was entitled "Chemicals and Health" and succeeded in generating considerable discussion among his very relaxed audience. The meeting was also successful in increasing student membership.

The next event in the Branch programme on 18 April was exclusively a result of the initiative and organising skill of Dr Brian Nicholson. His efforts have now resulted in the Chemical Magic Show appearing at branches throughout New Zealand with great success. Here at Waikato University an enthusiastic audience of nearly 400 senior school students were captivated by an evening which succeeded in being both educational and entertaining.

# HAZARDOUS AND LIQUID WASTE MANAGEMENT

*Are you satisfied with your company's waste disposal practices?*

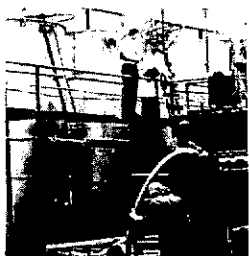

**M**anaging hazardous waste is an increasingly difficult and complex challenge and is a continuous process of responding with technology to the challenges posed by technology.

In addition to our New Zealand services to manage solid waste, Waste Management NZ Ltd has since 1985 operated a hazardous/liquid waste treatment facility in Manukau City.

Waste Management NZ Ltd is committed to the complex, on-going process of challenge and response necessary to ensure the safe and effective management of hazardous wastes.

Today, our services include:

- Waste removal and transport
- Emergency spillage response
- Consultancy
- Waste treatment and disposal
- Sample retrieval and analysis
- Recycling



*If you have a specific waste disposal problem, or an ongoing need for hazardous/liquid wastes treatment and disposal - or if you just wish to know more about us contact:*

### WASTE MANAGEMENT NZ LTD.

Hazardous/Liquid Wastes, 25 Diversey Lane, Wiri, PO Box 76108, Manukau  
PHONE: (09) 278 3644, (09) 278 2433. FAX: (09) 278 1975

### WASTE MANAGEMENT NZ LTD.

Box 356, Rotorua. PHONE: (073) 490 222. FAX: (073) 461 659

**WM** Waste  
Management N.Z. Ltd.



From the literally explosive opening, accompanying the strains of "Zarathustra", to the final spectacle of giant tuned flares of CS<sub>2</sub> in NO the audience was engrossed. The programme proper commenced with a cauldron of dry ice with indicators which demonstrated aspects of gaseous behaviour, sublimation and pH, after which a hapless teacher was persuaded to demonstrate a flaming breath test for alcohol. The chemistry of polymers was illustrated with the production of Nylon thread followed rapidly by a lesson in Dyeing and a number of Oxidation-reduction reactions, all convincingly presented. The properties of pure Oxygen, Guncotton and Hydrogen were evidenced by accompanying flames, flashes and explosions to the delight of the audience, who learned something about electrolysis at the same time.

Solubility was demonstrated to the discomfort of one participant, by means of a "race" to transfer innocent coloured liquids, followed by an absorbing display of cocktail colour changes involving reaction kinetics. Catalysis was shown in a variety of contexts and a most effective display of Oscillating Chemical reactions using Ultraviolet light led into a fascinating exploration of the mating habits of fireflies by means of Chemiluminescence.

The show was theatrically successful and the presenters, Dr Richard Russell and Dr Robert Schwitzer are to be congratulated on their efforts both as performers and educators. It is to be hoped that the target audience of senior school students will number significant converts to a career in Chemistry as a result of this show.

## CANTERBURY BRANCH NEWS

Branch Chairman Andrew Abell was born in Adelaide South Australia in 1960. He studied at the University of Adelaide, South Australia, from where he graduated with a B.Sc. degree in Organic Chemistry and Biochemistry (1981), a first class Honours degree in Organic Chemistry (1982) and a Ph.D in Organic Chemistry (1985). He spent two years a postdoctoral fellow at Cambridge UK with Professor A. R. Battersby before being appointed to the staff at the University of Canterbury, where he is currently a lecturer in the Department of Chemistry.

His research interests are in the field of Bio-organic Chemistry and in particular the design, synthesis and biological testing of latent reactive and conformationally constrained amino acid analogues.

## WRONZ NEWS

A Fellow of the Institute, Graham Jamieson has retired after 18 years at WRONZ, and 12 as Leader of the Wool-scouring Group. Graham came to WRONZ with a background in paper research, both in New Zealand and USA. During his

time with the very successful wool scouring group his particular areas of expertise were chemical treatments of wool in the scour, development of analytical methods for characterising scour liquors, evaluation of detergents, and improvements in effluent treatments. In 1983 he was seconded to the IWS UK to survey woolscouring practices in Europe. His many friends at WRONZ and elsewhere wish him and Valerie all the best in a very happy retirement.

Three new chemists have joined the Textile Chemistry Group.

Dr Gill Worth completed a post-doctoral appointment at Bristol University after finishing a Ph.D. at Otago. Gill will be working in chemical finishing of wool and molecular modelling of proteins.

Dr Warren Bryson, another Otago graduate joins WRONZ after running his own analytical service laboratory, Scientific Analytical Ltd. His main research areas at WRONZ are protein chemistry and chemical processing of wool.

Kathryn Gerard, a Canterbury honours graduate is involved in fibre structure work, particularly concerning the cell membrane complex.

## LINCOLN UNIVERSITY

A prominent Lincoln University staff member, Dr Kuan Goh has been honoured with a personal professorship in the Soil Science Department.

Professor Goh who has been on the Lincoln staff since 1971 is a specialist in the areas of soil fertility and fertilizers, nutrient cycling and soil chemistry. In a distinguished career he has been a Fulbright Scholar, a British Council Commonwealth University Interchange Scholar, an overseas consultant for the World Bank and guest lecturer at universities in the USA, UK, Japan and China.

## DSIR

Richard Vannort has transferred to DSIR Gracefield to perform toxicological work and start up supercritical fluid facilities.

## POLYTECHNIC

Dr Selwyn Maister was awarded a Fulbright Fellowship to visit the USA. Selwyn plans his visit to similar US institutions later in the year.

## FUNCTIONS

The popular barbeque function was held at the Ilam Homestead in March. Dr John Campbell of the Physics Department led a brave band of fire walkers across the hot embers.

The April meeting was a visit to Feltex Woven Carpets, Riccarton where the chief dyer, Keith Mitchell explained the intricacies of dyeing, colour matching, yarn processing and carpet manufacture.

A large and appreciative audience was educated, entertained, dazzled and

deafened by Richard Russell and Robert Schwitzer from Bond University, Australia who presented the Chemical Magic show to secondary school students and others at the University in May.

## CANTERBURY UNIVERSITY NEWS

Dr Ed Koubek from the US Naval Academy, Annapolis, Maryland is visiting the Department until mid May. Ed is working with Dr Don House on aspects of platinum chemistry.

Dr Melvyn Gill of the University of Melbourne is working with Drs Murray Munro and John Blunt until June. Melvyn's major research interests are the structure elucidation, synthesis, biosynthesis and stereochemistry of secondary metabolites (principally pigments) from Australasian fungi. While in New Zealand he is investigating some of our indigenous toadstools.

Prof. Philip R. Brooks from Rice University and the Rice Quantum Institute is in the Department for two months on an Erskine Fellowship. His research interests are in molecular dynamics and related topics, and he has pioneered several major advances in these fields. He is working with Dr Peter Harland and Prof. Leon Phillips during his stay, and is also presenting lectures to the Honours III physical chemistry class.

Dr Vickie McKee has recently returned from study leave. She visited Massachusetts Institute of Technology, the Centre d'Etudes Nucleaire de Grenoble and Queen's University, Belfast, and also attended several conferences. Her research work while she was away included studies on polynuclear iron and manganese complexes, cryptands and magnetostructural correlations.

Dr Rod Claridge has just returned from visits to Institut für Anorganische Chemie, Johann Wolfgang Goethe Universität, Frankfurt and the Department of Applied Chemistry at Osaka University. Among other things he studied the EPR and photochemistry of polymer precursors during his trip.

Dr Jim Coxon has recently returned from two months in America where he visited laboratories in California, Georgia and Florida and attended the Sanibel Symposia on atomic, molecular and condensed matter theory, computational methods and the application of fundamental theory to problems of biology and pharmacology.

Raewyn Town recently submitted her Ph.D. thesis: 'Studies on the Hydrophobic and Hydrophilic Properties of Humic Substances'. She will be taking a postdoctoral position in Geneva. Andrew Upton submitted his M.Sc. thesis on 'Applications of Magnetic Circular Dichroism'. Jan Wikaira has started a Ph.D. programme under the supervision of Vickie McKee. Kevin Jack and Katherine McGrath have both gone to Australia to start Ph.D.s, at the University of Queensland and the Australian National University, respectively.

# NEW GENERATION ON-SITE NITROGEN SYSTEMS FROM NZIG

Modern chemical processes in industry require cleaner and purer atmospheres during production, storage, packaging and transport. Inert atmospheres not only prevent contamination but also create safe conditions for what can be very volatile products.

NZIG is able to offer the chemicals and other industries cylinder and bulk supply nitrogen of 99.99 percent purity and on-site nitrogen generating systems.

Nitrogen, once regarded as a waste product of oxygen extraction, is now recognised as the most versatile of all the atmospheric gases. In steelmaking, heat treatment, metal fabrication and glass-making, nitrogen atmospheres prevent oxidation.

In a metallurgical application, a jet of nitrogen is blown into molten metal to produce a stream of atomised metal. This is directed onto a shaped collector, where it cools to form components comparable in quality to forged steel. The atomised metal can be mixed with alloys and ceramics to form composite materials with high strength-to-weight ratios.

Nitrogen is used in the paints and coatings industry during manufacture and in storage. It preserves the quality of the product and intermediates, preventing fires and explosions and controlling the rates at which intermediates react to form products.

NZIG offer two on-site nitrogen generation systems. One uses a pressure swing adsorption (PSA) sequence and the other, the membrane separation system, is the latest in on-site gases generation to come out of North America.

NZIG Gas Systems Manager responsible for on-site gas generation technology, Brian McMath, says on-site nitrogen generation is a lower cost form of supply as it eliminates the distribution element. "There is, however, a trade-off. The nitrogen generated is of a slightly lower purity and the systems cannot always cope with a sudden demand. For these reasons often customers use a combination PSA or membrane system in conjunction with a liquid nitrogen supply.

"The liquid supply can readily cope with peak fluctuating demands while the economics of the PSA/membrane processes favour constant demand."

## Nitrogen PSA Systems

Nitrogen PSA plants utilise carbon molecular sieves to separate out the nitrogen from air. Dried compressed air passes through a bed of carbon pellets which adsorb the oxygen and other trace gases.

The molecular sieve is derived from ground and oxidised coal. Each gram of adsorbent provides 1500 square metres of surface area in micropores of less than 40 Angstroms effective diameter. No chemical reaction is involved, merely a sticking

of oxygen to the adsorber material, so the molecular sieve will last indefinitely as long as the air supply is clean.

Two vessels of sieve material are incorporated into an NZIG Generon PSA system so while one is producing, the other is being regenerated. Air is supplied to the adsorber vessels from an air compressor which usually incorporates a buffer 'air receiver' and filter to remove contaminants such as oil or water.

Clean, dry air of less than 10 bar (g) then enters the bottom of the first bed where the sieve adsorbs the oxygen and other impurities, letting the nitrogen pass through. When this bed approaches saturation, it is depressurised to purge the sieve. Compressed air is then directed through the second bed to continue the adsorption process while the first one is being regenerated.

The bed which is on-stream is at least 0.2 bar to 0.5 bar higher than the regenerating bed and equalisation after venting the sieve takes the beds to approximately half the air feed pressure.

This continual pressurisation/depressurisation and swing between adsorber beds gives the process its name. The PSA system also removes carbon dioxide from the air stream so it can be used as a

keep apples in peak condition during months of storage.

By maintaining an oxygen level of only 2% in their 16 CA storage rooms, the respiration rate of the apples is slowed right down and ethylene production inhibited. The system is fully computerised and every half hour the atmosphere from every room is sampled by automatic analyser. Extra nitrogen is automatically injected into any room where oxygen levels are found to be increasing.

## Membrane technology

An advance in on-site nitrogen generation systems is the new membrane technology. Membrane air separation uses polymeric hollow fibres and works on a selective permeability principle.

Various gases have different permeation rates according to their solubility and diffusivity in the membrane, so as one might expect, hydrogen and helium permeate quickly while methane and argon are slower. Anomalies such as carbon dioxide and water which are faster than would be expected for their molecular size, have high solubilities in these polymers.

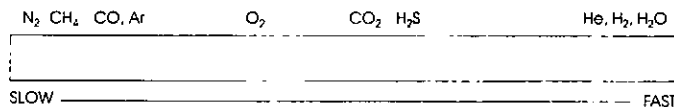

Figure 1 Hierarchy of Permeation Rates

scrubber for controlled atmosphere storage of fruit when programmed to a recirculatory mode.

Nitrogen purities up to 99.9% can be obtained from the NZIG Generon PSA system with outputs from 0.5m<sup>3</sup>/hr to 1200 m<sup>3</sup>/hr (34 tonnes/day)

## Blanketing Pharmaceuticals

New Zealand Pharmaceuticals (NZP) at Linton, near Palmerston North, have installed an NZIG Generon PSA system for blanketing and purging.

NZP produce and market raw materials for pharmaceuticals and extract fine chemicals from natural raw products. NZIG's on-site nitrogen PSA system provides an inert blanket over solvents and is used for inert purging of vessels and lines containing solvents.

With the emphasis on quality and safety, NZP have found the on-site nitrogen system the most cost effective way of ensuring their products maintain purity and ultra-high standards.

## Keeping apples crisp

The New Zealand Apple and Pear Marketing Board (NZAPMB) has installed an NZIG Generon Nitrogen PSA system at its huge coolstore complex in Hastings to

While membranes have been used for many years to carry out separations in the liquid phase by dialysis and electro-dialysis, their industrial use in the separation of mixtures of gases and vapours is still relatively new.

Polymer fibres contain no permanent pores through which the gas can flow. Instead, the polymer acts as a homogeneous solvent in which the gas dissolves to a well defined equilibrium concentration. The determining factors here are the nature of the polymer, the particular gas, temperature and pressure.

NZIG Generon membrane separation units consist of bundles of hollow fibre tubes (each with a diameter of half a human hair) in a high pressure shell. The fibre bundle is sealed at one end and encased in a tube sheet at the other. When mounted vertically, the bundle fills the shell ensuring uniform gas distribution.

Each fibre has a perfectly circular cross-section and a uniform bore through its centre. This consistent thickness is crucial to the physical strength of each membrane and for the fabrication of practical air separation equipment.

Compressed air up to 10.3 bar (depending on the size of the separator) is fed into

the base of the shell side of the fibre bundle and exits at the top, pressurising the inside of the individual tubes. As the air flows over the membrane, faster permeating gases (in this case oxygen, carbon dioxide, and water vapour) preferentially migrate into the fibre bore and are discharged through the base of the fibre bundle.

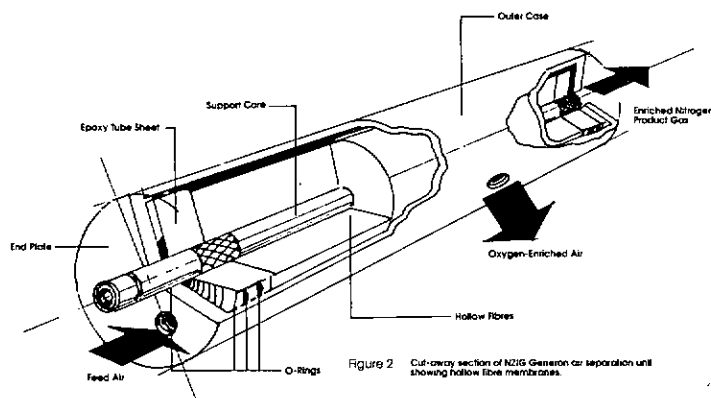

Figure 2 Cut-away section of NZIG Generon air separation unit showing hollow fibre membranes.

What remains is a single stream rich in nitrogen at essentially the feed pressure. Typically the pressure drop per module on the shell side is less than 0.2 bar. The other stream is rich in the faster permeating gas at a pressure of 10% to 50% of the feed pressure.

As water vapour also permeates out of the membrane with the oxygen, the end product is a dry nitrogen gas in a purity range of 95% to 99.9%. A slightly lower purity allows greater nitrogen production while slower gas production enables greater purity.

Membranes can also be used for separating hydrogen from nitrogen, methane and argon in, for example, the high pressure purge stream from an ammonia plant.

Hydrogen can also be separated from a mixture of hydrocarbons from oil refinery purge streams or separated out from carbon monoxide in petrochemical production plants.

NZIG's Generon membrane separation systems are similar to nitrogen PSA technology. The membrane separation system incorporates an air chiller to remove additional water (liquid/vapour) and compressor oil (liquid/vapour) to reduce the risk of module exposure to liquids contamination.

By maintaining a constant feed air temperature to the membrane a smaller compressor can be used, reducing capital outlay.

Generon Systems is a joint venture between NZIG's parent company, the BOC Group, and the Dow Chemical Company. Their respective expertise in PSA systems and hollow fibre membranes, has enabled the development of a new generation of nitrogen producing plant and Generon Systems are now market leaders in this area.

### Nitrogen purging

Nitrogen purging is a safe, efficient and reliable method of establishing a low oxygen atmosphere. Both membranes

and PSA systems utilise this method to lower oxygen levels for chemical purging applications and controlled atmosphere establishment.

Nitrogen gas is introduced into the room where it immediately mixes with the air. An equal volume of room air is vented out reducing the oxygen level at a constant rate. The amount of reduction in

the oxygen level is relative to the number of exchanges of the void storage volumes and the nitrogen purity of the purge stream.

The oxygen pull down rate is highest during the initial purging when the difference between the oxygen level of the room air and the purge stream air is largest. The higher the purity level of the purge stream, the faster the room oxygen level is pulled down.

For example, with a 100% nitrogen purge stream and perfect mixing of the gases in a room before the mixture is vented out, the oxygen concentration is reduced to about 7% with the first exchange volume.

After the second volume, the oxygen level will have decreased to less than 3%. On the other hand, with a 98% nitrogen purity, or 2% oxygen, of the purge stream the room's oxygen level is only reduced to 9% with one volume changed, and 4.5% with two volumes exchanged.

A standard purging formula applies to all applications whether tanks, vessels or controlled atmosphere rooms. To calculate the time required to achieve oxygen pull down to a specific level use the following equation —

$$T = \frac{V}{F} \ln \left[ \frac{C_i - C_p}{C_f - C_p} \right]$$

where

T = time, hours

V = void volume of storage (for controlled atmosphere storage use approximately 60% of empty volume)

F = purge gas flow rate

C<sub>p</sub> = purge gas oxygen concentration, %

C<sub>i</sub> = initial oxygen concentration, %

C<sub>f</sub> = final oxygen concentration, %

Brian McMath says PSA and membrane on-site generation systems are a natural extension of NZIG current range of gases supply options. "Gases are our core business and the fact these systems can make product on site doesn't alter the basic premise of a form of gas supply. They present opportunities for market extension in their own right or in combination with bulk supply.

"Through our membership of the BOC Group of Companies, we have access to international applications technologies. We also have a wealth of home grown experience which positions us favourably for choosing the best gas supply option for each customer's particular process development and/or application."

For further information on NZIG PSA or membrane nitrogen generating systems contact:

Brian McMath, Gas Systems Manager, NZIG Northern on Phone (09) 525-5600 or Fax (09) 579-2934.

Gerry Galbraith, Manager Gas Products, NZIG Southern Phone (03) 348-7199 or Fax (03) 343-0463.

## CA STORAGE PROLONGS FRESH PRODUCE LIFE

Tests, research and experience have proven the benefits of using nitrogen separators for controlled atmosphere (CA) storage and during the shipping of large quantities of fruits and vegetables.

For example, apples will maintain crispness and quality for over six months in CA storage using these systems. Asparagus will last for up to a month, bananas three months, kiwifruit over three months, nuts two or more years and tomatoes for up to six weeks before starting to deteriorate.

Increased storage life means growers and distributors can take advantage of increased consumer demands for year-round availability of seasonal produce, maintaining preferred prices.

Increased produce life increases distribution flexibility. Sea freight can be better utilised at a fraction of the cost of air freight and in much larger quantities.

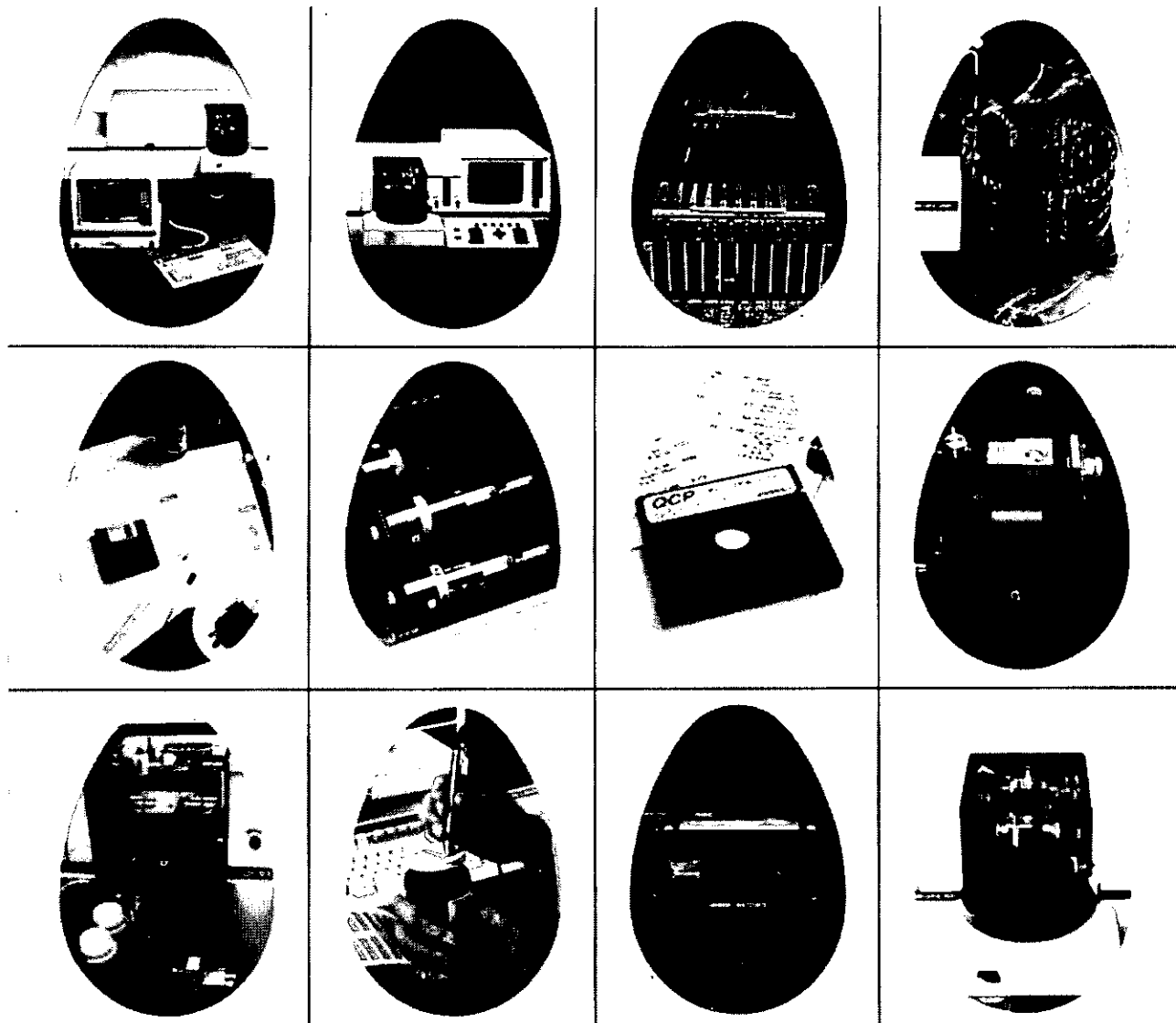

# A dozen good reasons to choose Varian AA

With the powerful SpectrAA series of atomic absorption spectrometers, you can select from dozens of state-of-the-art components. Such as the innovative VGA-76 for fully automated hydride and cold vapour analyses, and the GTA-96 with hot injection to enhance graphite furnace productivity.

Choose the spectrometer that suits your needs, from the moderately-priced SpectrAA-10/20 to the top-of-the-line SpectrAA-300/400. Central control from an IBM PS/2 Model 30-286™ ensures simple operation, extensive method and data storage, and access to dozens of software packages.

Take advantage of SpectrAA's features for fully automatic multi-element analyses, advanced sample handling, and powerful reporting capabilities. Varian's patented Zeeman Background Correction technology ensures fast, accurate correction of spectral interferences and structured background for every sample.

Add high performance accessories to your AA toolkit such as the Mark VI spray chamber and burner, the ACT-80 Atom Concentrator Tube, and productivity tools such as bar code readers for rapid entry of sample labels.

For consistent, quality results time after time, choose Varian AA. For further information, call the sole NZ agents today:



WILTON INSTRUMENTS

**People you can count on**

Auckland, Private Bag Northcote 9. Tel 418.3039  
 Lower Hutt, Box 31-044. Tel 697.099  
 Christchurch, Box 1813. Tel 366.3663

A member of the Salmond Smith Biolab group.

# Nikon for applications which demand precision

To meet today's increased demand for precision in quality control and research in a growing number of fields, Nikon offer a range of industrial microscopes to suit applications in biology, electronics, metallurgy, bio-technology, food science and much more.

From the range of measurescopes, profile

A complete range of accessories and attachments expand the capabilities of the microscope making photomicrography, TV monitoring, data processing, all modes of IC inspection, automatic wafer loading, and interferometry all possible, while enabling the operator to virtually custom-design the system.



SMZ-U

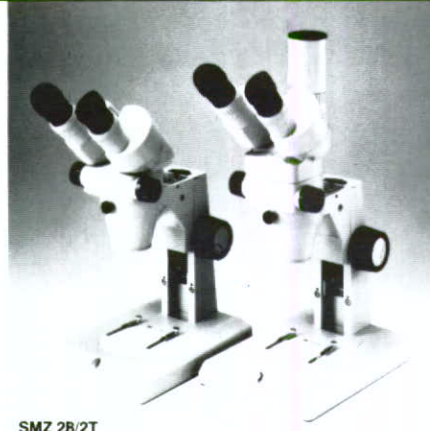

SMZ 2B/2T

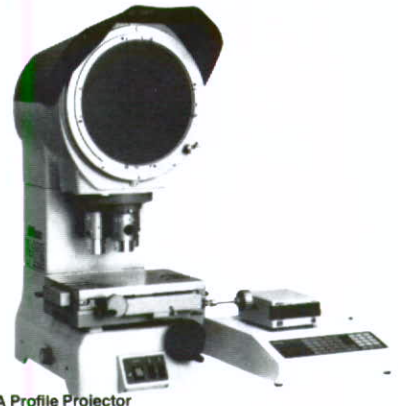

V-12A Profile Projector

projectors and inspection microscopes to a series of stereo microscopes with capabilities covering every user requirement, Nikon offer unsurpassed optical performance, outstanding ease of operation and versatility.



**WATSON VICTOR**  
Your Assurance of Quality.

Auckland P.O. Box 1216.  
Ph 579-3039 Fax 525-0951.

Wellington P.O. Box 1180.  
Ph 857-699 Fax 844-651.

Christchurch P.O. Box 706.  
Ph 669-282 Fax 662-537.

Dunedin P.O. Box 921.  
Ph 4777-291 Fax 4778-720.

6089A

## Fridurit® Laboratory Bench Tops



20,000 users can't be wrong! For more than 80 years Fridurit have supplied highest grade ceramic bench tops for use in chemical and testing laboratories.

### Consider These Advantages

- Chemically resistant except to hydrofluoric acid. Authentic test data on request.
- Self contained without any external support
- Extremely strong - high static strength and low coefficient of expansion
- Jointless
- Stand up to extremes of heat and cold
- Absolutely impermeable to liquids
- Scratch resistant
- Non-combustible
- Impact resistant
- Easy to maintain
- Simple to decontaminate
- Colour fast
- Not electrically conductive.

A phone call or a request on your letterhead will bring you a Fridurit leaflet by return mail.



### Thermoplastic Engineering Ltd.

*Pacemakers in Plastic Fabrication*  
151 Park Road, Miramar, Wellington, New Zealand.  
Box 15174, Wellington. Telephone (04) 882-092  
FAX (04) 887-523.

**SOLE  
NEW ZEALAND  
AGENTS**

TP23.

**NEW ZEALAND INSTITUTE OF CHEMISTRY (INC)**

# **FINANCIAL STATEMENTS**

**FOR THE YEAR ENDED 30TH APRIL 1991**

---

## **Index**

Income and Expenditure Account  
Balance Sheet  
Notes to the Financial Statements  
Auditor's Report

# INCOME AND EXPENDITURE ACCOUNT

FOR THE YEAR ENDED 30TH APRIL 1991

Last Year

## INCOME

Subscriptions from Members	98,130	109,034
Conference Surplus 1990	15,335	11,698
Chem 13 Exam Fees	302	2,743
Chem Education Subscriptions	250	425
I.U.P.A.C.	68	145
Chem 13 News	853	—
Interest — BNZ	7,014	6,960
Interest — Local Body Stock	31	31
Interest — NZI	—	587
	121,983	131,623

## EXPENDITURE

Accountancy/Audit Fees	2,598	2,099
Accommodation Expenses	446	3,638
Ballot Costs	—	1,125
Branch Expenses — Capitation Fees	11,880	14,010
Branch Expenses — Student Travel	2,500	3,000
Chem NZ Expenses	1,049	—
Chem 13 Expenses	2,331	508
Computing, Address Labels etc.	45	1,856
Conference Registrations	55	734
Conference Expenses	444	—
Donation	1,778	—
Depreciation	75	93
Freight	820	—
General Expenses	1,734	6,654
Honoraria & Allowances	69	1,405
Insurance	23	—
Interest & Bank Charges	737	542
Journal — Publisher	19,763	25,876
Journal — Editor	2,449	1,800
Sundry Publications for Resale	4,136	—
National Chemist Day Expenses	—	519
Overseas Visitors Expenses	204	500
Printing, Stationery & Postage	4,865	7,233
Prizes	491	1,520
Rent to I.P.E.N.Z.	1,788	2,689
Secretarial Services	35,636	9,980
Salaries	—	27,062
Secretarial Set-Up Costs	2,100	2,275
Subscriptions	2,210	5,131
Survey Expenses	—	3,000
Telephone & Fax Charges	1,913	1,478
Travelling Expenses — Internal	4,821	10,297
Travelling Expenses — External	—	1,747
	106,960	136,771
<b>NET PROFIT</b>	15,023	(5,148)

These accounts should be read in conjunction with the attached notes.

\_\_\_\_\_ *General Secretary* \_\_\_\_\_

\_\_\_\_\_ *Treasurer* \_\_\_\_\_

# BALANCE SHEET

AS AT 30TH APRIL 1991

Last Year

## CAPITAL FUNDS

Balance at the Beginning of the Year	31,714	36,862
Add Net Income	15,023	(5,148)
Development Fund	46,699	46,699
Easterfield Account	567	567
	<u>94,003</u>	<u>78,980</u>

## REPRESENTED BY:

### CURRENT ASSETS

Petty Cash on Hand	—	25
Prepayments: Re Future Conferences	2,000	1,000
Accounts Receivable	17,900	13,961
Prepaid Travel Account	395	1,372
Subscriptions in Arrears	2,000	19,410
Bank of New Zealand Current Account	1,584	10,907
B.N.Z. Autocall Account	71,291	62,777
Bank of New Zealand 02 Account	1,100	—
Interest PAYE	172	172
Stock of Wallcharts on Hand	525	24
Stock of Ties & Scarves on Hand	3,339	3,339
	<u>100,306</u>	<u>112,987</u>

### FIXED ASSETS

Office Equipment	582	582
Less Accumulated Depreciation	<u>284</u>	<u>209</u>
	298	373
Presidential Chain	<u>360</u>	<u>360</u>
	658	733

### INVESTMENTS

Equiticorp \$21,000 Debenture	1	1
Lyttleton H.B. Stk. 6.25% 1998	<u>500</u>	<u>500</u>
	501	501

### TOTAL ASSETS

101,465      114,221

### CURRENT LIABILITIES

Goods and Services Tax	3,837	5,379
Accounts Payable	3,425	29,862
Subscriptions in Advance	<u>200</u>	<u>—</u>
	7,462	35,241

### NET ASSETS

94,003      78,980

These accounts should be read in conjunction with the attached notes.

\_\_\_\_\_  
General Secretary

\_\_\_\_\_  
Treasurer

# **NEW ZEALAND INSTITUTE OF CHEMISTRY (INC)**

## **NOTES TO THE FINANCIAL STATEMENTS**

**FOR THE YEAR ENDED 30TH APRIL 1991**

### **STATEMENT OF ACCOUNTING POLICIES**

#### **1. GENERAL ACCOUNTING PRINCIPLES**

The general accounting principles recognised as appropriate for the measurement and reporting of earnings and financial position on an historical cost basis have been followed by the business.

Accrual accounting is used to match revenue and expenses.

Reliance is placed on the fact that the business is a going concern.

#### **2. PARTICULAR ACCOUNTING POLICIES**

The following particular accounting policies which materially affect the measurement of earnings and the financial position have been applied:

- : Accounts receivable are stated at their estimated net realisable value.
- : Inventories have been stated at the lower cost or net realisable value on a FIFO basis.
- : Fixed assets are stated at cost less aggregate depreciation. Depreciation has been calculated using the maximum rates permitted by the Commissioner of Inland Revenue and these are considered appropriate.

The rates used are as follows:

Office Equipment                      20% DV

- : These accounts have been prepared on a G.S.T. Exclusive basis.
- : Investments are stated at cost or, where applicable, with the addition of interest compounded to date.

#### **3. CHANGES IN ACCOUNTING POLICY.**

- : The accounting policies have not changed since last year.

## **AUDITOR'S REPORT**

### **TO THE MEMBERS OF THE NEW ZEALAND INSTITUTE OF CHEMISTRY (INC)**

We have audited the attached Financial Statements in accordance with accepted auditing standards and have carried out such procedures as we consider necessary.

In common with other organisations of a similar nature control over income prior to its being recorded is limited and there are no practical audit procedures to determine the effect of this limited control.

We have not sighted membership or subscription records and have received the Treasurer's certificate regarding subscriptions in arrears.

In our opinion the Financial Statements give, subject to the notes to the accounts, a true and fair view of the financial position of the Institute as at 30th April 1991 and the results of its activities for the year to that date.

15th August 1991  
AUCKLAND

MARKHAM & PARTNERS  
CHARTERED ACCOUNTANTS