

NZIC

Chemistry

IN NEW ZEALAND



METROHM 716 DMS TITRINO COMPUTER TITRATION POWER

John
Morris

Scientific

 **Metrohm**

*16 PC FTIR. Install
confidence in your Laboratory.*



- High quality optics
- Innovative design
- Reliable performance
- DOS, windows based software
- Experienced applications support
- Local service all mainland capitals

PERKIN ELMER
Measure us by our global strength

PERKIN ELMER PTY. LTD.

NEW ZEALAND BRANCH

11 Albion Road, Otahuhu, Auckland

P.O. Box 22-159, Otahuhu, Auckland

Ph 0-9-276 2230 Fax 0-9-276 5602

"NZIC AT THE CROSSROADS"

It is obvious to all observers that Science in New Zealand in relation to its teaching, practice and development has undergone and is still proceeding through a period of dramatic change and readjustment.

For most of us, irrespective of employment sector, the rude and harsh reality has been driven home that a career in science and Chemistry in particular is no longer to be considered as a job for life. Security is now a fond memory unlikely to return in the near future.

In the last year we have seen the demise of DSIR and other such organisations with massive redundancies of scientists and technicians. In the private sector many commercial labs have been closed and restructuring to central locations undertaken.

"Chemistry Division" the breeding ground of many brilliant ideas and careers has gone for good it would seem and with this central home of applied chemistry being removed an identity crisis for chemist is beginning to appear. This crisis is further deepened when one ponders the fact that the word CHEMISTRY is not to be found in the new Crown Research Institute systems at all.

Another problem is the increasing sophistication of laboratory instrumentation. Visit your local hospital laboratory and ask to chat with the chemists. More than likely they have been replaced with an automated chemistry unit controlled by a remote computer somewhere else in the building.

Modern X-Ray spectrometers are able to decide for themselves the type of sample that has been presented and to then select an appropriate analytical programme which will produce an element analysis for 30 or more elements to a precision of 0.5% or better. All of this with the lights off and no one in sight for hours at a time. Instrument faults can be diagnosed and often repaired by remote interrogation from the manufacturers premises on the other side of the world if need be.

In recent visits to Otago and Massey Universities I saw demonstrations of complex organic structures being developed, modelled and tested all via computer simulation. In industry computer controlled plant is to monitor, dose, analyse, sample and produce environmentally acceptable discharges to air and water for days on end without a chemist in site.

So what am I saying? Is Chemistry Dead? Are we like the dinosaurs who, having consumed their environment, slowly disappeared from the scene? To listen to some people one would almost think this was the case. It does look bleak out there. But are we any different to any other part of the community we live in. Have

Continued on page 72

From the President	55
Special feature: Fourier Transform Infra-Red Revisited	56
Improving the colour of wool	59
General News	62
Annual Report	64
Branch News	66
Conferences	66
Product News	67
Year Book Amendments	74

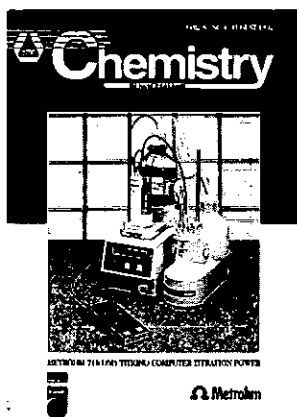

METROHM 716 DMS TITRINO - COMPUTER TITRATION POWER.

The DMS Titrino offers you 5 methods of analysis:

- Dynamic Titration
- Incremental Titration
- Set Endpoint Titration
- Karl Fisher Titration
- Measurements

All this in a titrator with a footprint no bigger than a sheet of A4 paper. The built in RS232 interface allows communication with a PC and printers.

Combined with the 716 Titrino is the 727 titration stand. Depending on the model you have the option of starting from above and below. Metrohm's philosophy regarding the communication between Titrinos, PC and peripherals means with a modest initial investment you purchase a fully functional compact high performance titrator to begin with which can later be supplemented by additional devices.

For further information contact: John Morris Scientific Ltd.
Auckland 0-9 444-5836, Lower Hutt 0-4 528-7600,
Christchurch: 0-3 653 825, Toll Free 0800 651700

Chemistry in New Zealand: Published on behalf of the New Zealand Institute of Chemistry (Inc)
PO Box 12-347, Wellington Ph: (04) 473-9414.
Fax (04) 473-2324
President: D.S. Winter, Hon. Gen. Secretary/ Executive.
Officer: Alan A. Turner, Hon. Treasurer: D.P. Karl.
Published six times a year in February, April, June, August, October and December.

Editorial: Technical and scientific article should be submitted to the editor no later than 1st of the month of publication, but much earlier for long articles. The editor will always welcome commercial and industrial news on product design, development and testing processing techniques, company and personal news etc.

Editor: R.B. Hall, 64 Mellons Bay Rd, Howick.
Phone (09) 534-9109

Publisher: Promotional Options, PO Box 101-189
N.S.M.C. Auckland 10.

Advertising: Carl Roze, Ph: (09) 521-5151

Commercial Editorial: Roger Whiting Ph: (09) 377-3570

Branch Editors:

Auckland: Dr Robyn Somerville, Mt Albert Research Centre DSIR, Private Bag, Auckland.

Waikato: Ron Newth c/- Chemistry Dept. University of Waikato, Private Bag, Hamilton.

Manawatu: Dr. Michael Boland, New Zealand Dairy Research Institute (NZDRI), Private Bag, Palmerston North.

Wellington: Adrian Bennet, BRANZ, Private Bag, Porirua.

Canterbury: Dr Robert J. Martyn Chem. Division, DSIR, PO Box 29-181, Christchurch.

Otago: Dr. George Emerson, Bio-Chemistry Department, University, of Otago, PO Box 56 Dunedin.

NOTICE ANNUAL GENERAL MEETING

The annual General Meeting of the NZ Institute of Chemistry will be held in Dunedin on Thursday, 17 September 1992, at the University of Otago, commencing at 7.30pm, to receive the Annual Report and Financial Statements.

By Order of Council
AA Turner
Honorary General Secretary.

FOURIER TRANSFORM INFRA-RED REVISITED

BY ROGER WHITING

My earliest experience with Fourier Transform Infra-red spectroscopy was in 1969 when I was an MSc student at University of Auckland. The Chemistry Department had an interferometer which produced an interferogram on punched paper tape. The tape was rolled up and taken down to the computer (IBM 1460) and several days later a dot diagram was waiting to be picked up. Joining the dots produced the far infra-red spectrum (200 - 30cm⁻¹) of the sample. The data was collected at the awesome rate of one bit per second which meant that the interferogram took about half an hour to run. As a check that all was going well there was chart recorder which had to be watched. This entailed spending half an hour be driven insane by the paper punch going jiggety jig, jiggety jig. The technique - like many in modern chemistry - has come a long way since those days with the development of lasers and computers.

HOW IT WORKS

The key part of any FTIR instrument is the Michelson interferometer which is shown in figure 1. The radiation from the light source is split by the beam splitter so that half of it goes to the fixed mirror and half

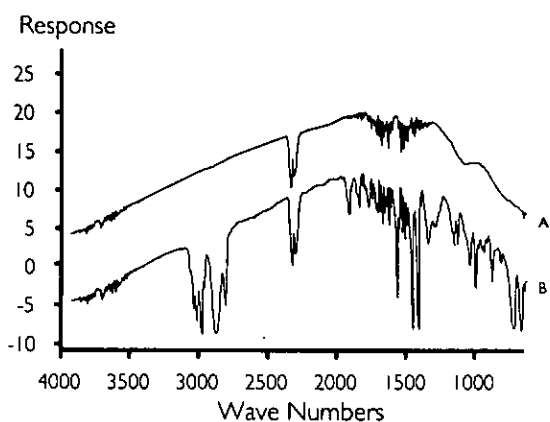

Figure 1. Courtesy of Bio Rad

Response from an FT-IR Spectrometer
Top: no Sample Bottom: with Sample

to the moving mirror. If the distance from the beam splitter to the two mirrors is the same then no matter what the wavelength of the light is coming from the source the light will interfere constructively and half will go back to the source and half will go on to the detector. This position for the moving mirror is called the ZERO PATH DIFFERENCE (ZPD) position and when the mirror is in this position the

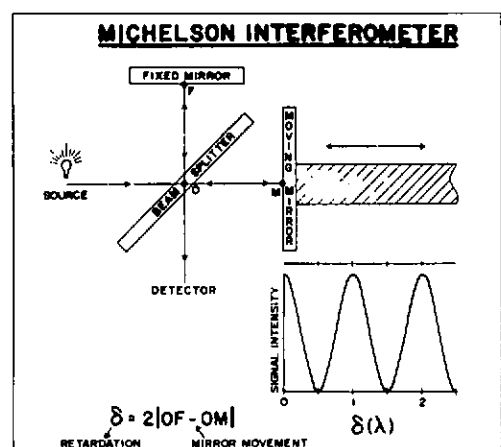

Figure 2 Courtesy of Digilab

interferogram shows a maximum. If the moving mirror is allowed to move forward or back from the ZPD then the light reflected back to the beam splitter will not all recombine constructively and a series of

maxima and minima are produced in the detector output as the light from the source recombines constructively and destructively. This pattern can be recorded and is known as an interferogram. After bouncing around in the interferometer the infra-red radiation is passed through the sample and on to a detector. By means of some mathematics it is possible to take the interferogram and calculate the wavelengths present in the infra-red radiation coming to the detector from the interferometer along with their intensities. The actual interferogram recorded is affected by the sample absorbing various wavelengths of the infrared radiation on its way to the detector. If no sample is present the spectrum obtained is that of the source. If a sample is present its absorption bands show as bands superimposed on the spectrum of the source. The spectrum of the sample can then be calculated by comparing the second with the first. In fact the first thing the FTIR does when switched on is scan and store a background spectrum which is the reference to which the the sample spectra are compared.

THE LASER

The advent of lasers greatly enhanced the field of Fourier Transform spectroscopy. The accurate calculation of the spectrum depends on an accurately recorded interferogram. To obtain this it is essential to know precisely the position of the moving mirror or its speed. For this a

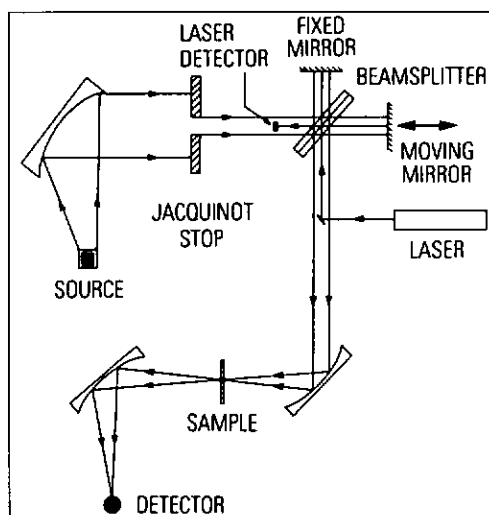

Figure 3 PUD800 FTIR Optical System (Courtesy of Philips)

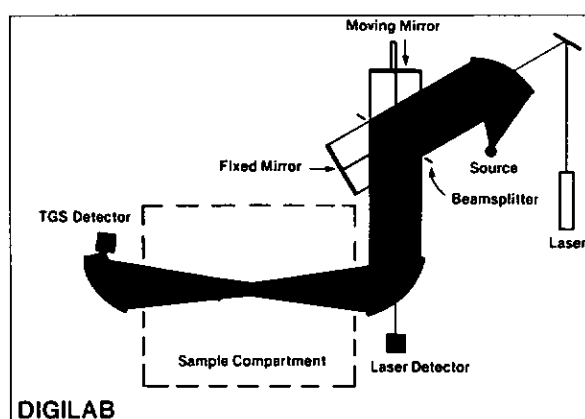

Figure 4. Courtesy of Bio Rad

laser is used. The laser beam is shone through the interferometer along with the infra-red radiation but in such a way that its beam can be detected separately from the infra-red. This seems to be done slightly differently by every manufacturer of FTIR equipment with each claiming

certain advantages for their particular configuration. Typical layouts are shown in figures 3 and 4. The laser produces a beam of monochromatic light. Thus its interferogram is a continuous sinusoidal wave. The position of the mirror can then be calculated accurately by counting the number of laser light peaks that have gone by. In practice the technique used is to start scanning the interferogram by moving the mirror. The appearance of the central maximum in the infrared indicates that the mirror is at its ZPD position. Then the distance the mirror has moved from that can be measured by counting the peaks in the laser beam detection as they come and go.

THE MATHEMATICS

The mathematics of the relationship between the interferogram and the spectrum is known as a Fourier Transformation. This operation connects the interferogram which is a function of detector signal intensity with the position of the moving mirror to the spectrum which is a function of intensity and wavelength or wavenumber. The mathematics have been known since 1891 but the size of the task of calculation meant that realistic use of the principle had to wait until the advent of cheap computing power.

Another breakthrough in the calculation field came in the development of an algorithm which significantly shortened the computing time for the process (1). This algorithm, developed by Cooley and Tukey in 1965 is sometimes known as the Fast Fourier Transform.

It is interesting to note that the mathematics of this process is frequently described in general terms but in fact is seldom discussed in detail. This is a case where the vast majority of chemists are prepared to leave the specialists to develop the tools while they themselves get on and use them. No one expects to be able to calculate a logarithm from first principles but chemists happily accept the use of pH so too here chemists are learning to accept that the mathematics takes the interferogram and turns it into a spectrum. Those that like to delve deeper into the mathematics might start with references (1) and (2).

ADVANTAGES OF FTIR

As users of FTIR most chemists merely notice that with FTIR they can obtain spectra much more quickly than using dispersive instruments and that the achievable resolution is often better. To those more deeply involved in instrumentation this is thought of as the result of a series of superiorities that FTIR has over dispersive instruments. Each one of these superiorities is called an advantage and each advantage bears the name of the person who thought of it or at least the person who publicised it.

FELLGETT ADVANTAGE

This relates to the speed of the instrument. As the dispersive instrument measures the intensity of each wavelength individually the amount of energy reaching the detector is very small. To compensate for this the instrument has to scan the spectrum slowly to achieve reasonable sensitivity. Thus spectra take three to four minutes to run. In the case of the Fourier Transform instrument half the source output reaches the detector. This means more energy in the detector so that the interferogram can be run relatively quickly.

This increased speed can be exploited in two ways. The most common is to run several (eg ten) interferograms and then average them. This reduces the noise level in the spectrum which means an increase in the sensitivity. This is feasible with dispersive instruments but the time required can make it tedious and as these instruments usually do not have the on board computing power that is essential in a Fourier Transform system it is not readily available. The other use of the speed advantage is to be able to measure the spectrum of samples that are changing rapidly. This can find application in for example kinetic investigations. Repeated spectra of the sample can show different species as they appear or are consumed. It can also be used to allow the recording of the infra red spectra of a chromatograph output so that species can be identified as they emerge from the column.

JACQUINOT ADVANTAGE

This also relates to the amount of energy passing through the optical system. In the dispersive instrument the wavelengths are selected by a combination of a grating and slits. High resolution requires the use of narrow slits which reduces the light reaching the detector. This then requires much slower scan speeds. The Fourier Transform instrument achieves a higher resolution by merely increasing the distance over which the moving mirror is passed. Thus increased resolution requires only a small increase in run time compared to the

dispersive instrument. This advantage is somewhat illusory for two reasons. Firstly most dispersive instruments give spectra of lower resolution than Fourier Transform ones which makes the scanning time more similar. Secondly the detectors used in dispersive instrument tend to be more sensitive than those on FT ones although with slower response.

CONNES' ADVANTAGE

This relates to the wavelength accuracy of the instrument and arises because of the accuracy of the laser system. Because the wavelength of the laser light is very accurately known the position of the mirror at any time during the scan is also accurately known. This means that when the Fourier Transform process is done the wavelengths of the bands can be calculated with great accuracy. Thus wavelength assignments are very accurate and peak identification is reliable.

SOME KEY WORDS

When chemists who are well versed in Fourier Transform technique discuss instruments they often use terms which need some explanation. Here are some of the more common ones which the novice may meet:

ADOPTIZATION - This refers to the way that the theoretical Fourier Transform process assumes that the mirror moves from infinitely far in front of the ZPD to infinitely far behind. In fact this is not possible and the distances are finite which results in some artifacts in the spectrum. These depend on how the adoptization is handled mathematically. If the interferogram is just cut off at the ends then it is referred to as BOXCAR but this can give rise to odd extra small peaks called RINGING. This is avoided by other mathematical treatments of the cut off of which there are many but TRAPEZOIDAL and TRIANGULAR are the names of the commonly used ones. These tend to remove spurious peaks.

ZERO FILLING - It the computer just joined the points of the spectrum it had calculate with straight lines the appearance would be jagged and hard to use. Zero filling is a way to fill in the dots and make it look "right".

COMPENSATORS - The material that acts as a beamsplitter has to be supported on a substrate through which the radiation passes. The radiation which is not reflected will have to pass through the substrate so that it will be slightly retarded relative to the reflected beam due to the refractive index of the substrate. This will upset measurement of the ZPD position which will cause the loss of accuracy. To solve this a slice of substrate is put in front of the beam splitter to give each beam the same amount of substrate to travel through.

SOURCES - The infra red radiation is produced by a source which tends to be one of two types. GLOBALARS are made from carborundum and are used at a high temperature. They require water cooling. Their advantage is long life and stability. NICHROME have the advantage of being cheaper and not requiring water cooling by are less stable and have a shorter life time.

DETECTORS - A commonly used detector is the THERMAL DETECTOR often using a THERMOELECTRIC material such as deuterated triglycine sulphate (DTGS). The electrical properties of DTGS change as it heats up in the beam and this gives a signal which can be measured. QUANTUM DETECTORS employ semiconductors. Their resistance decreases when infra red radiation strikes them. They are more sensitive but usually need liquid nitrogen for stable operation.

SINGLE SIDED INTERFEROGRAMS - Theoretically the interferogram should be symmetric about the centreburst. So time can be saved by measuring the interferogram on one side only and assuming the other side is a mirror image of the first. Alternatively the scan can go further from the centreburst and the resolution can be improved. In fact the interferogram is not quite symmetric due to PHASE ERRORS and a small scan around the centreburst is made to establish the PHASE CORRECTION that needs to be applied to make it symmetric.

1 W.D. Perkins *J. Chem. Ed.* 63(1) ppA6-a10 1986
2 P.R. Griffiths and J.A. deHaseb "Fourier Transform Infra Red Spectrometry" Wiley Interscience Publications New York 1986

MAGNA-IR

FT-IR SPECTROMETERS WITH OMNIC SOFTWARE



Simple, Versatile & Powerful

The simplicity you need to accomplish work in less time, the versatility necessary for ever-changing needs, and the power required to perform even the most challenging experiments—all in the Magna-IR series with OMNIC software.

Nicolet's team of engineers took the best available technology, learned through years of FT-IR experience, and combined it with innovative design improvements. The result? A family of spectrometers as functional as they are flexible and as intuitive as they are innovative—reliable performance, no compromises. Just flexible, high-performing systems that are extremely easy to use.



Science & Technology (NZ) Ltd

Nicolet
INSTRUMENTS OF DISCOVERY

From SCI TECH Head Office: 60 Willis Street PO Box 663, Dunedin New Zealand Ph 0-3 477 7860, Fax 0-3 477 7870

IMPROVING THE COLOUR OF WOOL

MARGARET LOENARD, JOHN MCLAUGHLIN AND HELEN GALILEE
WOOL RESEARCH ORGANISATION OF NEW ZEALAND (INC)

Wool as it comes off the sheep's back is covered with grease, pedological soil, wind-blown dust, vegetable matter, faecal material and suint (a sweat-like secretion). These contaminants need to be removed by scouring before the wool can be made into useful textile materials. The skill in wool scouring is to maximise the removal of the contaminants without reducing the value of the wool by entangling the fibres or reducing fibre length. New Zealand wool is renowned for its brightness, but occasionally scoured wool emerges much duller than expected. At WRONZ we have been investigating the reasons for such departures from normal quality.

The Wool Scouring Process

To understand how problems associated with wool colour may occur it is necessary to become acquainted with the scouring process. Greasy wool is teased open and dusted to remove large particles of sand and soil before washing in the scour itself. Figure 1 shows the layout of the WRONZ Comprehensive Scouring System, which is used by most wool

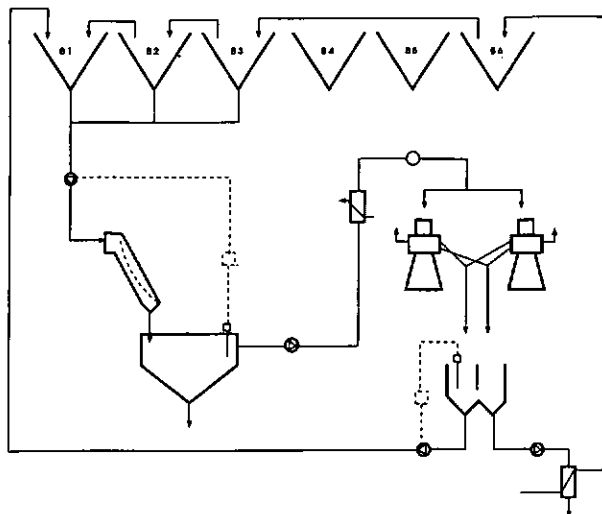

Figure 1: WRONZ comprehensive scouring system

scours in New Zealand, and by many overseas. To minimise effluent and efficiently use energy, the flow of wool and the liquors is counter-current. The first three scouring bowls, where the wool is washed, contain hot liquors (about 55-65°C) and progressively more dilute solutions of detergent and fleece contaminants as the wool moves along the scouring train. The scour liquor from the first bowl is continuously cleaned in a treatment loop. Wool fibres are removed through a wedge-wire screen and heavy dirt is settled before the liquor is passed through a centrifuge to separate grease. The cream which is recovered is further processed eventually to become lanolin. The cleansed streams are combined and a proportion returned to the first scouring bowl. The remainder of the liquor is discharged to drain. Minimum discharge to drain is practised to reduce pollution. The wool moves through the three scouring bowls to the rinse bowls. The rinsing process involves immersion first in two bowls of relatively clean cold water and a final immersion in hot water (65°C). This final hot rinse reduces the energy required for drying; more water is expressed by the squeeze rollers because of its lower viscosity, and the temperature difference between the wool and the air in the dryer is reduced.

Measuring the Efficacy of Wool Scouring

The colour of wool is measured by a reflectance colorimeter and can be described by the X, Y, and Z tristimulus values¹⁻³ corresponding to the red, green and blue receptors of the eye. The Y value may be used as a measure of the brightness of the wool and Y-Z a measure of the yellowness. Brightness and yellowness values relate easily to buyers

perception of the colour of the wool. The tristimulus values measured after collection from a scour are the 'scoured' tristimulus values. A second colour measurement, made after very rigorous cleansing in a detergent solution at 13500 r.p.m. in a Waring Blendor, gives the 'base' tristimulus values³. The difference between the two Y values (ΔY) indicates how the dirt present on the commercially scoured wool effects its brightness⁴.

$$\Delta Y = Y_{\text{base}} - Y_{\text{scoured}}$$

The higher the ΔY value the greater the effect the contaminants have on the brightness of the wool.

It is not possible to achieve the same Y value in a commercial scour as in laboratory cleansing. Commercially scoured wool never has $\Delta Y=0$, ie, $Y_{\text{scoured}} = Y_{\text{base}}$. In our work we have measured a range of ΔY values between 2 and 15. A value of 2 indicates excellent dirt removal; a value of 15 suggests a problem in scouring the wool. Other things being equal, the Y value depends on what type of wool is being scoured. Raw wool with little dirt will generally scour to a lower ΔY than a dirtier wool.

Redeposition of Soil During Scouring

Most of the mineral dirt (ash value) on commercially scoured wool is present at the tip of the wool fibre. The tip is the short section at the end of the fibre, which is permanently discoloured, owing to its exposure to the weather, and in the raw state is heavily contaminated with pedological soil. Removing it has little effect on the ΔY value because the colour of the tip wool is similar to the colour of the dirt. The remainder of the fibre, the butt, is much brighter. For the butt, there is a direct relationship between mineral dirt present and ΔY (Figure 2)⁵. Any mineral dirt which is deposited onto it will dramatically affect the brightness, in the same way that a spot of soil is much more noticeable on a bright white shirt than on a grey one.

X-ray fluorescence analysis of the mineral dirt removed from commercially scoured wool by Dr J. Hunt, Soil Bureau, indicated that it was clay. Normally clay minerals occur as aggregates which are easily removed from the wool because of their size. However, if a wool scour is operated in the most economical way, with minimal water discharge, these particles can remain in the system for hours or even days. Under conditions of long residence time, high temperature, and continuous pump action, the clay aggregates can swell and be sheared into tiny plate-like particles⁶. The resultant increase in particle surface area makes it easy for the particles to redeposit, while the reduction in size and plate-like shape makes them more difficult to remove^{6,7}.

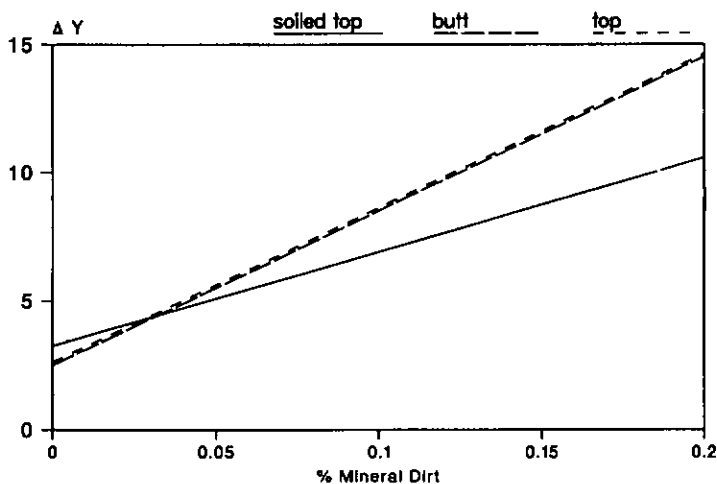

Figure 2: The effect of mineral dirt on ΔY

Redeposition of the mineral dirt during scouring was tested using thoroughly cleaned wool top (wool which has been scoured, carded into a sliver and combed)⁴. Samples of top were passed through commercial scour liquors and their colour measured before and after cleaning in the Waring Blender. Figure 2 indicates a similar direct relationship between the mineral component of the dirt which had deposited from the liquors and the Y value, as was observed on the butts⁵. This relationship between mineral dirt on a normally bright substrate and ΔY was again tested by depositing different amounts of finely ground, oven-dried soil onto clean wool top⁵. A similar relationship between the amount of mineral dirt and the improvement in brightness was observed (Figure 2). Comparison of the slopes of the lines for artificially soiled top and the samples of wool which had been through a commercial scour are different, suggesting that mineral dirt alone is not the only cause of dull colour in commercially scoured wool.

Chemical Changes in the Mineral Dirt

We believe that another contaminant is an iron sulphide-like material⁸. The conditions for the formation of iron sulphides, ie, reducing conditions, ferrous iron and sulphide can be present under scouring conditions. After about 30 hours of scouring the scouring liquors in bowls 1 and 2 become anoxic and chemically very reducing with redox potentials of about -350mV. Always present on raw wool is soil containing iron oxides, and this accumulates in the scouring bowls. Degraded wool protein and residual depilatory paint (a mixture of sodium sulphide and lime) from slipe wools (wools removed from pelts in the freezing works) are two sources of sulphide.

Although wool scoured under such conditions is initially grey, the contaminant becomes brighter and more yellow with time. This behaviour is consistent with the colour changes observed when iron sulphide oxidises in air to iron oxide, changing from black to orange. On wool this is consistent with an increase in brightness and yellowness. The increase in yellowness is caused mainly by the loss of the black surface coating rather than by the formation of a yellow iron oxide layer.

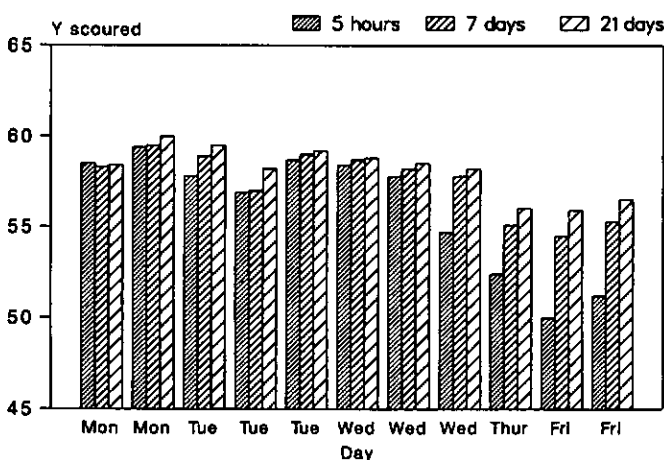

Figure 3: Changes in brightness of wool tops

Neither X-Ray diffraction nor X-Ray fluorescence of the black particulate material which is formed in the scouring bowls over time can conclusively identify iron sulphide. Iron sulphide prepared in the laboratory also appeared to be too amorphous to be identified by X-Ray diffraction. Although identifying iron sulphide in an environment which is rich in both iron and sulphide has proved to be very difficult, the behaviour of the contaminant is consistent with that of iron sulphide, as the following example indicates⁸.

If samples of wool top are passed through a commercial scour over a week and the brightness of each sample is measured at particular time intervals (after 5 hours, after 7 days and again after 21 days) the increase in brightness with time is greater for samples taken at the end of the week (Figure 3). More dramatic are the changes observed in the yellowness (Y-Z) of the top (Figure 4). The types of wool being scoured over this period and the conditions of the liquors provide the necessary sources of iron and sulphide. In this example the last four samples (which are

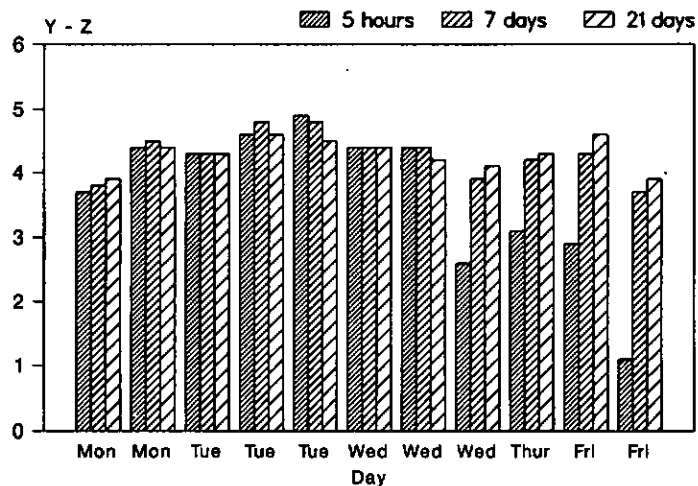

Figure 4: Changes in yellowness of wool tops.

the most dramatic) were collected during the scouring of a slipe wool, a dirty line (two samples), then another slipe line. The wool type scoured before these samples was a crossbred, which contained mineral dirt (iron source). Slipe wool contains sulphur-rich residues which can react with the ferrous iron under the reducing conditions measured in the bowls. When the line changes to a dirty blend there is still plenty of sulphide (from the slipe wool) and a renewed source of ferrous iron (from the mineral dirt). Since it normally only takes a few hours for the sulphide from slipe to be consumed another source of sulphide must be present. Over the week of scouring degraded wool from broken fibre tips or very short fibres can accumulate in the liquors providing an important second source of sulphide (cystine is an important constituent of wool keratin). The brightening and yellowing of the wool does not coincide with the greatest concentration of iron in the liquors, which occurred midweek, nor does it correlate with the amount of acid-extractable iron on the wool top. The amount of iron extracted from the last sample on Friday is about the same as that extracted from the first sample on Tuesday, yet the behaviour of the samples is quite different. It is not the absolute amount of iron present that matters, rather the form in which it occurs.

Conclusions

The production of unusually dull scoured wool can occur when mineral dirt is redeposited as tiny plate-like clay particles on the brightest part of the fibre. Iron sulphides can be generated during scouring under conditions of low redox potential, high mineral dirt and the presence of sulphide and deposit on the wool. Its major effects are observed as a dull grey scoured wool which gradually brightens and becomes more yellow. Understanding the nature of these two contaminants has enabled us to advise scourers on ways to minimise colour problems.

This work has been funded by the New Zealand Wool Scourers Association and the New Zealand Wool Board.

References

- Hammersley, M.J. and Thomson, B., WRONZ Commun. No. 27 (1974).
- Hoare, J.L. and Thomson, B.J. Text. Inst., 65, 281-287 (1974)
- New Zealand Standard NZS 8707:1974
- McLaughlin, J.R. and Leonard, M.M., WRONZ Report R168 (1989).
- Leonard, M.M. and McLaughlin, J.R., Proc. Int. Wool Text. Res. Conf., Christchurch (1990).
- Power, W.C., Detergency: Theory and Technology, ed. W.G. Cutler and R.C. Davies, Marcel Dekker, New York (1972).
- Powe, W.C., Text. Res. J., 29, 879-884 (1959).
- McLaughlin, J.R. and Leonard, M.M., accepted by Text. Res. J.

Do you require any of these gases in your laboratory?

- Zero Air - High purity, hydrocarbon free air for use with Gas Chromatograph FID detectors.
 - Clean, dry air for use with analytical instruments and equipment such as NMR Spectrometers, AA Spectrophotometers, Thermal Analyzers etc.
 - Clean, dry, CO₂ free air for FT-IR Spectrometers.
 - Ultra-high purity nitrogen/hydrogen for gas Chromatography ets.
 - Carrier/Combustion gas for total organic carbon (TOC) analyzers.

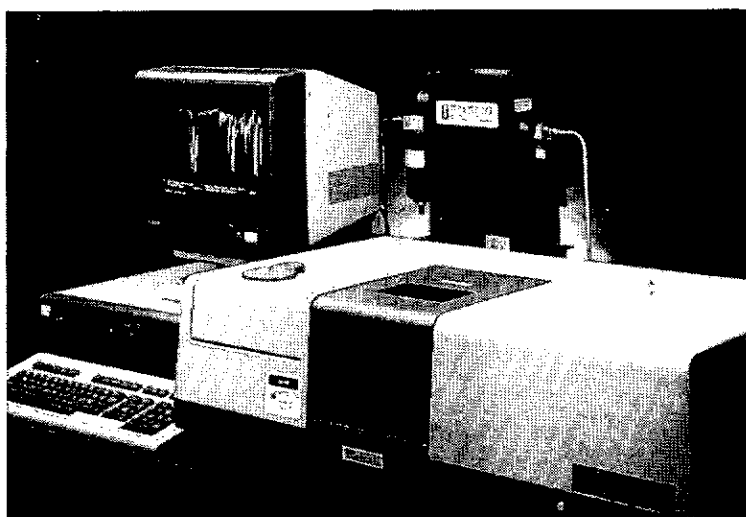

We can offer you an alternative to gas cylinders with the Balston range of gas generators and purifiers giving you the benefits of:

- **Increased safety in the lab by eliminating heavy, hard to handle gas cylinders.**
 - **No hassles of recalibration from cylinder to cylinder.**
 - **Long term savings in cost of gases.**
- **Zero Air Generator**
 - **Compressed Air Dryer**
 - **Air Dryer/CO₂ Remover**

Demonstrations or trials of the following units can be arranged:

For further information, mail or fax this form, or phone:

Bill McSweeney, Wilton Instruments, PO Box 31-044 Lower Hutt, Wellington

PH 0-4 569-7099 Fax 0-4 569 7240 South Island customers can phone 0800 809 023 Toll Free

I am interested in the range of Balston gas generators and purifiers. Please send me further information on the following:

- Zero Air Generators for GC
- Air Dryers
- Air Dryers/CO₂ Removers for FT-IR
- Hydrogen Generators for GC
- Nitrogen Generators for GC etc
- TOC Gas Generators

- Please phone me to discuss my requirements

(Please check those which apply)

Name _____
Position/Title _____
Department _____
Company/Institution _____
Address _____

Phone (0) _____
Fax (0) _____

GENERAL NEWS

TEACHERS WANT TO KNOW ABOUT SCIENCE AND TECHNOLOGY IN INDUSTRY

Science teachers want to know more about the application of science and technology in industry according to research carried out by ICI New Zealand Limited.

Teachers say that they value the importance of links between schools and industry. They want to spend time with industry to learn about the applications of science, and would like industry to provide classroom teaching resources.

In a survey of 425 science teachers throughout New Zealand for which there was a 28 percent response, ICI found that three-quarters of the teachers rated highly the importance of spending time in industry. The majority agreed that from one to two weeks was the ideal length of time.

ICI New Zealand General Manager, Graeme Boyd said the survey was carried out to measure the effect of the work that the Company was doing in science education.

The Company has provided classroom teaching resources and as a trial, gave a science teacher the opportunity to work for four weeks in a research and development area of the company.

"We wanted to measure the effectiveness of the resources we have provided. We wanted to sound out teachers on what they thought about industry involvement in science education and about the value of placing teachers in industry. We knew through our trial placement of a teacher last year that it works but we needed to know the attitudes of science teachers generally.

"Science teachers have told us in this survey that what we have done is of value to them and to their students. More importantly, they have given us the direction for future involvement," Graeme Boyd said.

The importance of links between industry and schools was considered very important or greater by 81 percent of science teachers. The involvement of industry in providing classroom resources was rated very important or higher by 72 percent.

The importance of placing teachers in industry was seen by 75 percent to be very important.

Asked how did they rate the importance of participating in a teacher placement programme, 92 percent considered this as either very or extremely important.

Fifty five percent of the teachers felt that the ideal length of time a teacher should spend with industry was one to two weeks although 27 percent thought that one to two days would be sufficient.

The reaction by science teachers to ICI's classroom resources was positive with the majority wanting more material. The level of interest among students in the material was rate high.

While teachers rated highly the relevancy of the resources to their teaching in spite of their overseas origins, all would like to see resources based on New Zealand own natural resources and processes.

CHEMICAL OLYMPIAD

Four of New Zealand's top chemistry students have been chosen to compete in this years Chemical Olympiad to be held in the United States. The team is:-

Nicholas Cutfield	17 of Dunedin	(Otago Boys High School)
Michael Fleming	16 of Mt Eden	(Auckland Grammar)
Henry Liu	18 of Epsom	(Auckland Grammar)
Andrew Lowe	18 of Remuera	(Selwyn College)
Stephen Hodge	18 of Hamilton	(Fairfield College), is the non-travelling reserve.

The team was picked after a five day training and selection camp at Auckland University for 14 secondary students from around the country. They will compete against contenders from 30 countries in Pittsburgh, Pennsylvania and Washington DC in July.

The team will be accompanied by Dr Robert Maclagan, Chemistry Department, University of Canterbury and Dr Sheila Woodgate, Chemistry Department, University of Auckland.

We offer our congratulations to the team members and wish them well in the competition.

STOP PRESS: We understand that medals were won! More details in next issue.

PROPOSAL FOR THE FORMATION OF A MATERIALS SCIENCE SPECIALIST GROUP

It is proposed that a Materials Science Specialist Group be set up under the umbrella of the NZ Institute of Chemistry. The expectation is that any one who works with any aspect of materials, whether in Industry, in a University environment, or as an interest (e.g. ceramicists), could become a member. It is hoped that the group will bring together all aspects of Materials Science from fabrication to usage and from properties to mechanical/physical testing.

The aims and objectives of the proposed specialist group can be summarised as follows:

The main aim of the proposed materials group is to bring together all those interested in the concept of materials and associated technological sciences.

It is perceived that the members be provided with an opportunity to discuss all aspects of the science manufacturing technology and use of materials. The discussion may take the form of formal or informal gatherings, seminars or meetings; it may take the form of papers and conferences, or it may take the form of industrial or related visits.

The diversity of the subject allows for a wide range of ideas and concepts to be put forward for a large variety of materials.

There are a considerable number of industries within New Zealand interested in the production, fabrication and usage of a huge range of materials. Until now a lot of the knowledge has only been seen within a small group of people. It is highly likely that within the area of Materials Science the "reinvention of the wheel" syndrome occurs on a large scale. This new group hopes to overcome this and allow much greater interaction between people working within the field.

The main areas will be the properties, fabrication and uses of ceramics (including fine ceramics, industrial and engineering ceramics and electronic ceramics), metals (including alloys), polymers (including wood) and composite materials. The idea of well established technological materials and not so well established materials could be looked at. Areas of interest of specific problems could also be discussed within the group.

It is hoped that all those interested in the area of Materials Science get involved in the group; New Zealand is, after all, an innovative country and that innovation should be brought to light to others interested in it.

If you are interested in joining the group, or if you would like further information, please contact:

Dr Nigel Sammes, Centre for Technology, University of Waikato, Private Bag 3105, Hamilton, tel: 07 838 4065, or contact the NZIC direct; Their address is: Executive Officer NZ Institute of Chemistry, PO Box 12-347 WELLINGTON 6038

REPORT COMMENDS INTERNATIONAL REPUTATION

A review of the Chemistry Department has commended its high international reputation and suggested ways to meet the challenges it faces in the 1990s. The 11-person committee conducted its review in August 1991 after meeting several times earlier in the year and receiving submissions. Its brief was to examine:

- The department's activities in meeting its commitment to the academic study of chemistry, to the University and to the community;
- The department's undergraduate and graduate programmes compared with those in other institutions in New Zealand and overseas;
- The quality of the department's teaching and research in chemistry;
- The appropriateness of departmental organisation and resource availability.

Chemistry has been taught at the University since its establishment as Auckland University College in 1883. The department was created in 1914 and has since won worldwide recognition for its academic achievements, especially in inorganic and organic synthesis, and the high quality of its graduates. Many past and present staff members have received high academic honours.

Challenges currently facing the department include the ageing of its building and equipment, reduced staff numbers and funding, a change in the departmental headship and management, proposed changes in Science Faculty administration, and the University's entry into the Foundation for Research, Science and Technology public good science pool.

The committee's report covered resource provision, organisation and administration, teaching, research, student affairs, interactions with others, accommodation and services, safety, and future directions. It suggested that the department prepare, in consultation with staff members, a five-year strategic plan covering its teaching, research and administrative responsibilities.

The committee recommended that the department strive to maintain its current student-to-staff ratio to avoid erosion of its high standard of chemical education.

It also suggested the development of a staffing plan, as part of the wider strategic plan, to help meet its anticipated teaching and research needs.

Organisational changes in the department introduced by the new HoD met with the committee's general approval as did the weakening of the department's sectional structure, and the promotion of research collaboration and equipment sharing.

To further improve consultation with the department the committee suggested the inclusion of a general staff representative on the newly formed Departmental Committee.

General staff play a key role in the Chemistry Department, the committee said. It recommended a review of technical staff deployment with special regard to laboratory service staff and the demands resulting from sophisticated new instrumentation, and redefinition of the roles of the chief technical officer, purchasing officer and administrative assistant.

The review indicated that standard of degree training in the department are high. The committee stressed the need for all staff teaching stage one to have opportunities for advanced teaching and association with research groups. It also recommended that students majoring in chemistry should complete core papers covering organic, physical, inorganic, and instrumental and analytical chemistry. Course co-ordinators for stages two and three should be appointed and a yearly curriculum review should be completed by the Committee of Section Heads to assist them. The review committee suggested the introduction of a paper to help prepare chemistry graduates for applied chemistry tasks in the workplace.

To compete more effectively in an increasingly competitive research environment the department should expand its interdisciplinary and multidisciplinary research programmes, the committee suggested.

The committee highlighted two special concerns in the area of research funding - the need for highly skilled technical staff to operate sophisticated equipment cost-effectively and the "inadequate" funding for chemicals and other consumable laboratory supplies.

To promote student involvement in the department, the review team suggested that introduction of a mentoring scheme, and the formation of a Chemistry Club. Responsibility for chairing the existing Staff-Student Liaison Committee could also be passed to students.

The review commended the "positive interactions" department staff have developed with high schools. It encouraged the department to collaborate more with other chemistry departments in New Zealand and to improve its association with industry in this country.

The Chemistry Department review committee was chaired by Professor Roy Sharp (Chemical and Materials Engineering, now Dean of Engineering). Other committee members were Professor N. Barlett (University of California, Berkeley), Professor Pat Bergquist (Zoology, Academic Committee chair), Professor Philippa Black (Geology), Dr Ted Bollard (University of Melbourne), Professor A. McKillop (University of East Anglia), Professor Alistair Renwick (Biochemistry), Professor Paul Williams (Geography), and Dr A. Wilson (DSIR).

QUOTE: UNIVERSITY OF AUCKLAND NEWS

**Monitor Silica Levels
in the Water/Steam Circuits
of your power plant
with Bran+Luebbe's
MONITOR 90**

- continuous monitoring
- microprocessor controlled
- low level silica detection to 1 ppb
- low reagent consumption
- auto calibration
- multi stream

BRAN+LUEBBE
Alpha Laval (N.Z.) Ltd.
Sandwich Road, Hamilton
Phone: (07) 849 60 20 - Fax: (07) 8 49 66 60

ANNUAL REPORT

INCOME AND EXPENDITURE ACCOUNT FOR THE YEAR ENDED 30TH APRIL 1992

INCOME	1991	
Subscriptions from Members	98,628	98,130
Sundry Income	303	-
Conference Surplus 1991	11,042	15,335
Chem 13 Exam Fees	2,151	302
Chem Education Subscription	569	250
I.U.P.A.C.	555	68
Chem 13 News	2,505	853
Interest - BNZ	6,451	7,014
Interest - Local Body Stock	31	31
Equiticorp Capital Repayment	161	-
	<u>122,396</u>	<u>121,983</u>

Chemical Olympiad Donations	5,195	-
Chemical Olympiad Expenses	<u>5,195</u>	<u>-</u>

EXPENDITURE	1991	
Accountancy & Audit Fees	2,687	2,598
Accommodation Expenses	4,288	446
Branch Expenses - Capitation Fees	10,764	11,880
Branch Expenses - Student Travel	3,500	2,500
Chem NZ Expenses	3,927	1,049
Chem 13 Expenses	2,142	2,331
Computing, Address Labels etc	-	45
Conference Registrations	378	55
Conference Expenses	505	444
Donation	-	1,778
Depreciation	60	75
Freight	-	820
General Expenses	-	1,734
Goods & Services Tax	(5,412)	-
Honoraria & Allowances	-	69
Insurance	-	23
Interest & Bank Charges	1,248	737
Journal - Publisher	43,655	19,763
Journal - Editor	3,600	2,449
Sundry Publications for Resale	1,029	4,136
Overseas Visitors Expenses	450	204
Printing, Stationery & Postage	8,059	4,865
Prizes	900	491
Rent to I.P.E.N.Z.	2,565	1,788
Secretarial Services	42,600	35,636
Secretarial Set Up Costs	2,363	2,100
Subscriptions	3,460	2,210
Telephone & Fax Charges	935	1,913
Travelling Expenses	<u>8,236</u>	<u>4,821</u>
	<u>141,939</u>	<u>106,960</u>

NET EXPENDITURE OVER INCOME	<u>19,543</u>	<u>(15,023)</u>
------------------------------------	---------------	-----------------

CAPITAL FUNDS	1991	
Balance at the Beginning of the Year	46,737	31,714
Less Net Expenditure over Income	19,543	(15,023)
Development Fund	46,699	46,699
Easterfield Account	567	567
	<u>74,460</u>	<u>94,003</u>

REPRESENTED BY: CURRENT ASSETS

Prepayments: Re Future Conferences	-	2,000
Accounts Receivable	4,589	17,900
Prepaid Travel Account	986	395
Subscriptions in Arrears	3,289	2,000
8th Australian Electrochemistry Conference	2,233	-
B.N.Z. Current Account	2,272	1,584
B.N.Z. Autocall Account	64,453	71,291
B.N.Z. 02 Account	-	1,000
Interest PAYE	141	172
Stock of wallcharts on hand	-	525
Stock of tiles & scarves on hand	<u>3,000</u>	<u>3,339</u>
	80,963	100,306

FIXED ASSETS

Office equipment	582	582
Less Accumulated Depreciation	344	284
	238	298
Presidential Chain	<u>360</u>	<u>360</u>
	598	658

INVESTMENTS

Equiticorp \$21,000 Debenture	1	1
Lyttleton H.B. Stk. 6.25% 1998	<u>500</u>	<u>500</u>
	501	501

TOTAL ASSETS	<u>82,062</u>	<u>101,465</u>
---------------------	---------------	----------------

CURRENT LIABILITIES

Goods & Services Tax		3,837
Accounts Payable	2,832	3,425
Subscriptions in Advance	1,150	200
Chemical Olympiad		-
Donations in Advance	<u>3,620</u>	<u>-</u>
	7,602	7,462

NET ASSETS	<u>74,460</u>	<u>94,003</u>
-------------------	---------------	---------------

NOTES TO THE FINANCIAL STATEMENTS FOR THE YEAR ENDED 30TH APRIL 1992

STATEMENT OF ACCOUNTING POLICIES

1. GENERAL ACCOUNTING PRINCIPLES

The general accounting principles recognised as appropriate for the measurement and reporting of earnings and financial position on an historical cost basis have been followed by the business. Accrual accounting is used to match revenue and expenses. Reliance is placed on the fact that the business is a going concern.

2. PARTICULAR ACCOUNTING POLICIES

The following particular accounting policies which materially affect the measurement of earnings and the financial position have been applied:

- Accounts receivable are stated at their estimated net realisable value.
- Inventories have been stated at the lower of cost or net realisable value on a FIFO basis.
- Fixed assets are stated at cost less aggregate depreciation. Depreciation has been calculated using the maximum rates permitted by the Commissioner of Inland Revenue and these are considered appropriate.

The rates used are as follows:

Office Equipment	20% DV
------------------	--------

- These accounts have been prepared on a G.S.T. inclusive basis.
- Investments are stated at cost, or where applicable, with the addition of interest compounded to date.

3. CHANGES IN ACCOUNTING POLICY.

- This years accounts have been prepared on a G.S.T. inclusive basis. Last years accounts were prepared on a G.S.T. exclusive basis.

AUDITOR'S REPORT

TO THE MEMBERS OF THE NEW ZEALAND INSTITUTE OF CHEMISTRY (INC)

We have audited the attached Financial Statements in accordance with accepted auditing standards and have carried out such procedure as we considered necessary.

In common with other organisations of a similar nature, control over income prior to its being recorded is limited, and there are no practical audit procedures to determine the effect of this limited control.

We have not signed membership or subscription records and have received the Treasurer's certificate regarding subscriptions in arrears and advance.

Subject to the possible effect of the limited control over income referred to in the preceding paragraph, in our opinion the Financial Statements give, using the historical method, a true and fair view of the financial position of the Institute as at 30th April 1992 and the results of its activities for the year ended on that date.

Auckland

Markham & Partners
Chartered Accountants

TREASURERS REPORT

The 1991/92 Institute accounts have been audited and are presented here.

The following details should be noted and the sets of accounts read accordingly.

As stated in the Notes to the Financial statements, there has been a change in the way the accounts have been prepared in that G.S.T. has

been included in the amounts reported.

If we adjust the income and expenditure account to take this into account then we see that total income has fallen from \$121,983 to \$108,796 and that expenses have risen from \$106,960 to \$126,168.

The proposition of the income derived from subscriptions was \$87,669. This represents a fall of 11% over the previous year of \$98,130 subscription income.

The most obvious contribution to the increase in expenditure is the item -Journal- Publisher. Some of this can be explained by the very erratic publishing dates in the early part of 1991 forcing two issues of the journal over into the 1991/92 financial year.

If this is taken into account then the smoothed results should read something like - surplus for 1990/91 year of \$5,023 (actual \$15,023) and deficit for 1991/92 year of \$7,543 (actual \$17,371).

This points to a realistic journal cost of something like \$34,000 annually in its present form. This represents 39% of subscription income.

The other major item of expense is the secretariat. This has not increased significantly over the previous year and represents 43% of subscription income. These items together account for 82% in total of subscription income.

Members have expressed strongly that both these items are essential to the Institute.

You have expressed strongly that the Institute should not make an excessive 'profit' from members attendance at the Institute conference. In the 1992/93 financial year there will be no contribution to income from conference.

Therefore the likely income (total) for 1992/93, based on present trends, is going to be in the region of \$86,000 to \$96,000. If expenditure is maintained (adjusted journal cost basis) at \$121,000 then we are looking at a potential deficit of between \$25,000 and \$35,000.

This can be met out of cash reserves, but only for a little under two years, or three years if there is a substantial contribution from the next conference.

The reason for substantial fall in subscription income have been identified to some extent, ie unemployment, ageing population, change in job content, lack of recruitment etc.

The trend of decreasing income and increasing expenditure is now becoming obvious. Action will have to be taken to reserve this situation if we are to maintain the services you as members want.

WEST-WALKER McCABE

Patent & Trade Mark Attorneys
Intellectual Property Law

- PATENTS ▪ TRADEMARKS
- DESIGNS ▪ COPYRIGHT
- INTELLECTUAL PROPERTY
- LICENSING

Call for an obligation-free discussion

Tel 04-382 9085

Fax 04-473 0466

Fraser House 160-162 Willis Street
PO Box 215 DX 8961 Wellington 1

BRANCH NEWS

OTAGO NEWS

Dr Geoff Kelsall, Reader in Electrochemical Engineering, Imperial College, London spent four weeks in the Chemistry Department as a William Evans Fellow. He presented research seminars on "Photoelectrolysis" of Colloidal Semiconductors and "Electrochemical Flue Gas Desulphurisation" and also carry out collaborative research on electrodeposited colloids with Jim McQuillan.

Dr Bhadra Munasira, who is a senior lecturer in Chemistry at the Open University of Sri Lanka, arrived in the Chemistry Department on sabbatical leave in September 1991. Dr Munasira, whose interests are in electrochemistry and analytical chemistry, is working with Keith Hunter on applications of palladium-hydrogen electrodes to coulometric analysis.

Dr M.R. Grimmet has recently returned from study leave mainly spent in the Chemistry Department, University of Salford, Manchester. There he collaborated with Dr Brain Iddon on a review of "Azole Lithiation", as well as commencing a major survey of "Heterocyclic Halogenation". A short period at the Open University was spent looking at the use of video tape film and computer learning programmes in chemistry teaching. Attendance at the International Chemistry Education Conference at York in August proved a highlight with much of the programme devoted to methods of improving the teaching status and perception of chemistry in educational establishments and in the community.

Salford University is fortunate in having **Dr Iddon** on its staff. Not only does he have a worldwide reputation in heterocyclic chemistry research, but he is actively involved in chemical safety programmes. He travels all over the U.K. with his "Magic of Chemistry" lecture, and manages to fit in the job of housing officer on Bolton (pop. 250,000) Council. Salford Chemistry Department has another Otago graduate on its staff, **Professor John Spencer**, who is Pro-Vice Chancellor at present. Those who knew John as a student in the 1970's will be delighted at the outward transformation.

Professor P.K. (Peter) Grant retired at the beginning of 1992 after 42 years association with the University of Otago as a student and then staff member. Peter has continued to be very active in teaching and research throughout his career, and in the last few years has also taken a keen interest in technical services in the University. Many of his former students were able to be present at a farewell function in the department, at which a Prize fund to mark his achievements was announced. Peter will continue to have a room in the department and we all look forward to many more years of having Peter working with us.

In February, **Dr Eng Wui Tan** took up the position of lecturer at the Department of Chemistry.

A PhD (organic chemistry) graduate of the University of Adelaide he joined the Harvard Medical School in Boston, in 1990, as a postdoctoral research fellow working in the field of bio-organic chemistry. His present research centres around enzyme-substrate-inhibitor interactions aimed at the design of pharmaceuticals. Also February, **Dr Alan R Hayman** was appointed lecturer in the Department of Chemistry. Alan, did his undergraduate work and PhD at postdoctoral work, at the Dunedin of the North (Edinburgh) with Dr Bob Baxter on structural aspects of protein signal sequences. Current research interests include glycopeptides, peptidic host-guest chemistry and biological applications of N.M.R.

Dr Rob Ledger formally of the CIT has joined the School of Pharmacy at Otago as a Senior Lecturer. Rob was an active member of the Wellington Branch in which he held office.

Dr Wayne Temple who has served for some time as Acting Director has been appointed Director of the National Toxicology Group at the Otago Medical School. Although having assumed more administrative duties Wayne will continue his active interest in the hazards presented by industrial chemicals and poisoning caused by drugs and other agents.

CONFERENCES

THE ROYAL AUSTRALIAN
CHEMICAL INSTITUTE



NINTH NATIONAL CONVENTION

December 6-11, 1992

MONASH UNIVERSITY
CLAYTON, VICTORIA, AUSTRALIA

REGISTRATION

National Conventions are the major meetings of the Royal Australian Chemical Institute and are held at approximately four-year intervals. The Ninth National Convention (9NC) will therefore be the largest and widest ranging gathering of chemists in Australia for some time. 9NC will be held on the campus of Monash University, situated 20km from the Melbourne city centre. The Monash University campus is ideally suited for a large conference; the lecture rooms, student Hall of Residence, banking facilities, parking and meals are all within easy walking distance.

Most of the Divisions of the Royal Australian Chemical Institute: Analytical Chemistry, Cereal Chemistry, chemical Education, Colloid and Surface Science, Electrochemistry, Environmental Chemistry, inorganic Chemistry, Medicinal and Agricultural Chemistry, Organic Chemistry, Physical Chemistry, Polymer, and Solid State will participate in the 9th National Convention. Invitations to present plenary lectures have been accepted by leading Australian chemists and a wide range of overseas speakers of the foremost calibre in all these areas of chemistry. The Divisions will meet together for Convention lectures and all other activities of common interest. They will also hold separate conferences in their specialist areas during 9NC, and in a number of cases several Divisions will meet together for Joint Symposia on subjects of mutual importance. An extensive Instrument and Equipment Exhibition will also be held. NZIC Members: For registration forms for this important conference, apply to Alan Turner, your NZIC Branch Secretary, the Secretary of your specialist Group or the Chemistry Department NZIC representative at your University.

MALAYSIAN INSTITUTE OF CHEMISTRY - SILVER JUBILEE CONGRESS

The Institute Kimia Malaysia (Malaysian Chemical Institute) is celebrating its Silver Jubilee (1967-1992) by holding the Malaysian Silver Jubilee Chemical Congress on 17-19 November, 1992 in Kuala Lumpur. The Congress will comprise symposia on Modern Analytical Techniques, Chemical Education, Environment, Polymers, Oils and Fats and Popularisation and Public Understanding (of chemistry/sciences). A copy of the announcement brochure is available from this office.

The President would be pleased to hear from any of our Members who may be attending this Congress. Please advise the Executive Officer in the first instance if you intend to participate.

- 5 ACC 93 5th Asian Chemical Congress
- 2 ANAIC 93 2nd Asian Network for Analytical and Inorganic Chemistry
- CHEMIDEX 93 Chemical and Industrial Exposition, Asia 1993

The above events will be held in Kuala Lumpur, Malaysia on 8-11 November 1993. Brochures and Registration forms are available from the Executive Officer.

PRODUCT NEWS

NICOLET

Recently, Nicolet had their international release for a new series of FTIR spectrometers. Known as MAGNA-IR they incorporate some exciting new innovations, many of them patented.

The entry level spectrometer in the MAGNA-IR series is the model 550 which incorporates novel features such as a patented ceramic EVER-GLO IR source requiring no external utilities and with a five year warranty. Ever-Glo is stable and extremely reliable and offers the best sensitivities in the industry. The new VECTRA is the world's first interferometer driven by a digital signal processor (DSP). The DSP controls all scan parameters including X-mirror position, velocity, filtering and dynamic alignment.

The foundation of the MAGNA-IR series is the precision cast STABILIZER baseplate. The Stabilizer, combined with the STONEHENGE pinned-in-place, diamond turned mirrors enhance system stability and maintain perfect optical alignment over time.

All MAGNA-IRs have resolution options to better than 0.1cm^{-1} and can be upgraded on site if your resolution requirements change.

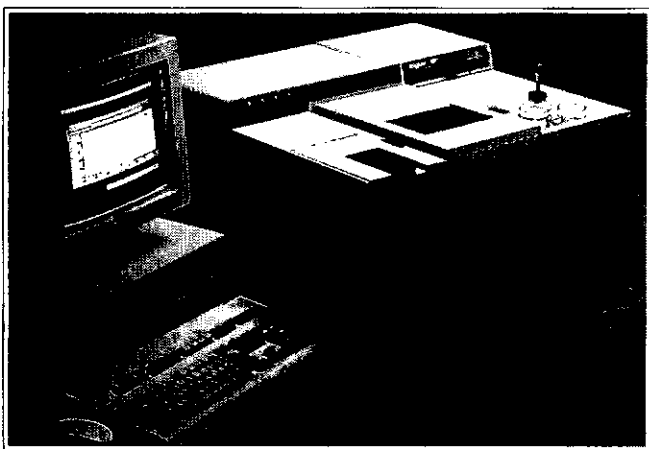

External beam ports on either side of the MAGNA-IR enable you to add auxiliary sampling accessories utilising the shortest possible infrared beam path. The exclusive MONOFLECT dual detector option incorporates your choice of two detectors simultaneously. A computer controlled mirror automatically positions the beam on the detector you select. If you want to extend the spectral range of the MAGNA-IR it takes less than 10 seconds to alternate beam splitter and detector.

With OMNIC, spectrometer control and data collection are as easy as clicking the mouse on a desired function. You can select parameters, align the system, collect real-time spectra and perform system diagnostics with one touch of the mouse. The sophisticated configuration menu for the optical bench provides a real-time update of system performance factors including signal strength, aperture, velocity and gain.

Spectra-Tech, the inventors of FTIR Microscopy and the leaders in quality FTIR accessories, are now a wholly owned subsidiary of Nicolet and are represented exclusively in New Zealand by Sci-Tech.

For more information on Nicolet and Spectra-Tech products please contact Sci Tech, P O Box 663, Dunedin.

Head Office: 60 Willis Street PO Box 663, Dunedin New Zealand Ph 0-3 477 7860 Fax 0-3 477 7870

SHIMADZU FT-IR INSTRUMENTATION

Shimadzu have recently launched the FT-IR 8000 series of Fourier Transform Infrared Spectrophotometers incorporating novel interferometer design advances to assure excellent long-term optical performance.

Two models offer a choice in resolution. The FT-IR 8101 series with 2cm^{-1} resolution is best suited to the majority of users application needs,

while the FT-IR 8501 offers 0.5cm^{-1} resolution for more demanding requirements.

The systems are as easy to use as dispersive instruments. However they offer all of the advantages inherent in Fourier

Transform technology and can be easily upgraded to offer high level applications such as IR microscopy.

The lack of wearing parts in the interferometer, automatic alignment system and sealed optics provide easy and stable long term operation even in humid conditions. The large colour VDU display screen provides a clear view of many spectra and also permits easy expansion of multiple spectra important for comparison purposes. Incorporation of context sensitive HELP functions ensures that even inexperienced users will be obtaining useful results in the minimum of time.

Additionally the systems incorporate as standard an IR analysis guide, a type of expert system software giving the operator useful advice on the most appropriate sample preparation methods and accessories to use in the analysis of particular samples.

A wide variety of data processing functions are included as standard and the multiprocessor control system allows data processing of one analysis while another sample is being measured. Spectromacro is a user definable macro program function that allows automation of most of the spectrometer operations including acquisition and file management tasks.

For further information contact:

Douglas Scientific

PH: 09 837-5447, FAX: 09837-5446,

P O Box 45-027, AUCKLAND 8

OUTSIDE AUCKLAND FREEPHONE: 0800 735 725

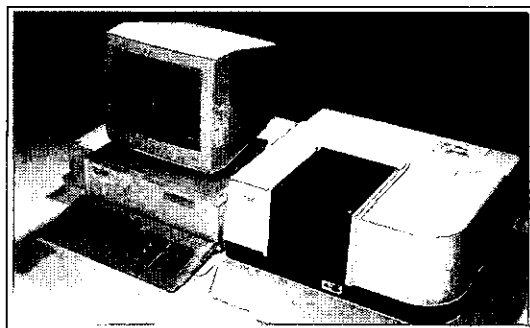

THE DA8 DYNAM ALIGNMENT 8CM OPTICAL BEAM

Bomem is in a unique position to offer you the DA8, a product with advanced technology, but based on many years of experience in research grade FT-IR design, manufacture and support.

Advanced Technology

- Bomem patented dynamic alignment. Full time active interferometer alignment with less than 1 microradian residual alignment error.
- Fast self aligning after beamsplitter changeover.
- Time compensated wide band signal amplification with oversampling for immunity to mirror velocity variations.
- Bomem patented real time numerical filtering with Forman phase correction and efficient data management.
- Advanced optics and detector technology for unsurpassed sensitivity.
- Advanced system integration and interfacing to a wide variety of measurement arrangements.
- Advanced multi-function High Performance Vector Processor (HPVP).
- Industry standard DEC-VAX host computer with VMS based multi-tasking multi-user software including built in networking.

Spectroscopic Performance

- Exceptional precision of instrument response function due to consistency of modulation with dynamic alignment.
- Exceptional spectroscopic sensitivity in all spectral ranges due to optical throughput, low transmission loss and high modulation efficiency.

- Internal; absolute frequency accuracy to $\pm 0.0004\text{cm}^{-1}$ at 2000cm^{-1}
- High photometric precision and low artifact content even under harsh conditions of operation.
- High long term stability for long measurement sequences.
- High precision and sensitivity including radiometric calibration for weak emission spectroscopy.

THE BOMEM MB SERIES FT-IR

The MB Series FT-IRs are based on the modern "wishbone" interferometer design. This has permitted the realization of an FT-IR with unusually high spectroscopic performance features at a low price. By design and through sound manufacturing methods, the MB 100 gives you many years of dependable service. There are no complicated optical realignment procedures or costly maintenance steps: Worry-free, trouble-free FT-IR. The universal optical bench provides a roomy sample compartment with industry standard center focus beam. It accepts the majority of commonly used accessories. For more dedicated sampling arrangements such as flow through liquid or gas cells, or an ultra stable

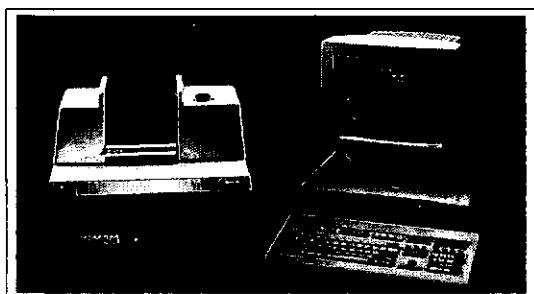

monolayer film reflectance accessory or cryostats or autosampling arrangements, you can quickly interchange the entire sample compartment. Ask about the different sample compartments available or design your own.

THE MICHELSON 100

The MICHELSON 100 is a complete FTIR system optimized for a maximum stability and sensitivity at 4cm^{-1} resolution using a room temperature DTGS infrared detector. The MICHELSON 100 features permanently aligned optics that do not need readjustment even after lengthy transport; an open architecture sample compartment that can be configured to meet specific needs; a sealed cast aluminium interferometer housing that protects the KBr beamsplitter, optics, electronics, and infrared source; a maintenance free interferometer design; a complete IR analysis software package operational on IBM-PC, IBM-XT or IBM-AT type computers; a 2-year warranty on parts and labor; and a 30-day guarantee of satisfaction period. The data system includes an IBM-AT compatible computer system, monochrome or optional colour display, and menu driven software. The sample compartment features a focused sample position, a removable sample plate, a sample chamber cover, and connections for purging. An operator's manual is included.

For further information on Bomem Fourier Transform Spectrometers Contact:

**Alpha Tech Systems,
P O Box 37-583, AUCKLAND
PHONE: (09) 377-0392 OR (04) 389-3905
FAX: (09) 309-8514**

FULL-FEATURED, POWERFUL FTIR MIDAC

Choice of Resolution

M Series spectrometers provide a full range of resolution, from 2cm^{-1} for routine analysis up to 0.5cm^{-1} for high resolution work such as gas and multicomponent analyses (all models are step selectable down to 32cm^{-1}). In addition, you are never "locked in" to your original instrument's capability. Resolution upgrades are simple with reasonably priced upgrade kits available from the factory.

If a standard spectrometer package just won't do, several options are available. The standard air cooled source can be replaced with an optional high energy, water cooled source for extremely demanding

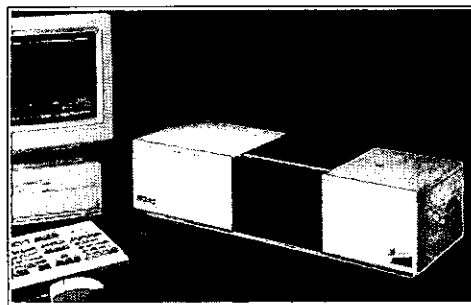

systems, so you can adjust to a wide range of samples and applications without wasting time.

THE MIDAC M SERIES FTIR SPECTROMETER

Rugged Design and Versatile Optics

Rugged construction for real world operating conditions enables M Series spectrometers to perform reliably in both laboratory and hostile process environments. High system throughput allows you to obtain useful data from traditionally difficult, low transmission samples.

Flexible Sampling Options

A generous sample compartment easily accommodates standard inboard sampling accessories such as liquid flow cells, gas cells, ATR, and many others. M Series models are also available with collimated beam output ports. An external beam enables you to make full use of today's powerful new sampling equipment. Now you can move the power to FTIR directly into your chemistry.

For further information contact:

ICI Instruments

P O Box 68-330, Newton, AUCKLAND

PH: (09) 373-5765

FAX: (09) 360-0683

MOBILE: (025) 920-833

FTIR FOR PERKIN ELMER 1600 SERIES FTIR SPECTROMETERS

The 1600 Series Spectrometers are cost-effective, high performance instruments for quality control, analytical and teaching laboratories, featuring a sealed and desiccated optical bench, built-in VDU keyboard. The new range includes two models with optional CsI beamsplitters for the analysis of organometallics and inorganic compounds.

The Model 1605 FTIR is especially suited to the educational laboratory and operates over the spectral range $4400\text{-}450\text{cm}^{-1}$

The Model 1615 FTIR with a spectral range of $7800\text{-}350\text{cm}^{-1}$, is designed for the quality control laboratory. This instrument uses the advanced acquisition and manipulation software, Compare software for screening incoming raw materials and checking finished products and Method software for the full automation of IR analyses.

The Model 1625 FTIR offers additional flexibility, with an external beam facility suitable for microscopy or an additional sampling compartment and a disk drive for data storage. Both instruments can be upgraded to include Search and Quant software.

For more demanding instruments the Models 1650/1650(F) are available with a spectral range of $7800\text{-}2350\text{cm}^{-1}$ and $7800\text{-}200\text{cm}^{-1}$ respectively.

Spectral Search and curve-fitting QUANT software is standard, making this instrument ideal for method development and analytical services laboratories.

Also available is the Model 16PC/16PC(F) controlled by an industry-standard 386-based PC, and using the Infrared Data Manager (ERDM) Release 2 software, a sophisticated windowing environment featuring a mouse-based user interface, extensive interactive data commands and complete instrument control.

THE SYSTEM 2000R NEAR-INFRARED FT-RAMAN SPECTROMETER

Designed for ease of use and high sample throughput, the Perkin-Elmer System 2000R is an optimized FT-Raman spectrometer with optional infrared capability. Gold coated mirrors, f/0.6 collection optics, high throughput filters and a proprietary detector design combine to give unmatched sensitivity.

Real-time spectral monitoring and pre-aligned sampling devices, unique to Perkin-Elmer, ensure that the best performance is always achieved. A large sample compartment with remote X, Y, Z sample adjustment and 900/1800 excitation provides maximum flexibility for research applications.

A calibrated reference source is provided to remove instrumental response characteristics from Raman spectra. Without this background correction relative band intensities would be misleading.

Raman and infrared spectrometry are complementary techniques and weak IR vibrations such as -C=C- and -S-S- stretches, which are of particular interest in the polymer industry, show strong Raman bands.

As glass is a good window material for Raman samples, valuable materials may be examined non-destructively in the original container, and polymorphic pharmaceuticals, sensitive to pressure and grinding, may be examined undiluted, without preparation.

For further information contact:

Perkin-Elmer New Zealand
P O Box 22-159, AUCKLAND
PH: (09) 276-2230
FAX: (09) 276-5602

THE NEW SYSTEM 2000 FTIR

Perkin-Elmer's System 2000 is a totally new concept in FTIR spectroscopy, designed specifically to meet the changing requirements of analytical and research chemists. The concept is based upon open architecture design in the three key areas of sampling, optical configuration and data handling.

Open sampling architecture is achieved by discarding the conventional internal and external sample compartments in favour of an interferometer module with up to four equivalent output beams arranged symmetrically at the four corners.

Each output beam can be configured with a sampling station, including single and double sample compartments, FTIR microscopes, GD-IR interface, TG-IR interface and Near-IR FT Raman.

The optical symmetry means that today's sampling requirements can be met, leaving the system open for upgrades or reconfiguration.

System 2000's optical flexibility allows multiple sources, beamsplitters and detectors to be fitted to the same unit to cover all or any part of the range 15,000 to 20cm. In addition, an external source position and auxiliary detector input means that any new developments can be added without compromise. At the heart of the system the proprietary Dynascan interferometer self-compensates for dynamic alignment errors and can deliver a resolution of 0.15cm⁻¹.

Open data handling on System 2000 means using an industry-standard 386-based or faster computer platform so that the system fits easily into virtually any laboratory software and network environment. Perkin Elmer uses parallel-processing Transputer technology in order to provide computer power equivalent to a top-of-the-line workstation.

For further information on Fourier Transform technology contact:

Perkin Elmer New Zealand
P O Box 22-159
AUCKLAND. Ph 0-9 276 2330, Fax 0-9 276 5602

DIGILAB FTIR FROM BIO-LAB LABORATORIES

Digilab currently manufactures three series of FTIR spectrometers. The FTS-60 Series uses a new state-of-the-art interferometer that can, among other capabilities, be used to perform time-slice experiments at 6 μ sec resolution. The FTS-40 Series is a high-performing instrument that has a place in the research laboratory as well as the analytical laboratory. The FTS-40 is the world's most popular spectrometer as a modest price. Both FTS-40 Series and FTS-7 Series instruments can be controlled through either a Bio-Rad or PC data station. The PC data station uses software from Galactic Industries: Spectra Calc or Lab Calc.

Digilab manufactures an experience range of infra-red sampling accessories including FT-IR microscopes, GC/FT-IR interfaces, thermal analysis interfaces, specialized oil and gas analysis systems, ATR accessories, photoacoustic detectors, fibre-optic accessories and diffuse reflectance accessories.

Digilab FT-IR instruments are used in New Zealand in areas such as:

- Forensic analysis
- QA/QC of plastic and polymers
- University teaching and research
- Forest and timber research
- Gas analysis
- Soils analysis

Digilab sponsors regular New Zealand User Group Meetings. New Zealand FT-IR training courses and frequent visits to New Zealand by overseas researchers.

For further information contact Bio-Rad Laboratories
New Zealand headquarters in Auckland: PO Box 100 051
Auckland
Ph 0-9 443 3099 Fax 0-9 443 3097
Toll Free 0800 805 500

IR ACCESSORIES FROM QUALLS SCIENTIFIC SERVICES LTD

Qualls Scientific Services Ltd was established in 1989 to provide FT-IR clients throughout New Zealand with a convenient source of infra-red sample handling accessories. The company acts as agent for a number of specialist manufacturers of spectroscopy accessories covering, mainly, the infra-red. Major agencies include:-

- **BUCK SCIENTIFIC**
General purpose infra-red cells, crystals, oil-in-water analysis instruments, dispersive infra-red instruments
- **SPECAC**
General purpose infra-red cells, crystals, ATR accessories, fibre-optic accessories
- **HARRICK SCIENTIFIC**
General purpose infra-red cells, crystals, ATR accessories, diffuse reflectance accessories, custom optics.
- **MTEC**
Photoacoustic detectors

Qualls Scientific Services Ltd also acts as agents for **FINNIGAN MAT** Mass Spectrometer Systems and **NALORAC** NMR probes.

For further information, contact Qualls Scientific Services Ltd,
606 Gloucester Street, Christchurch .

Phone: (03) 389-5046 or Fax: (03) 381 2529.

PH: (09) 276-2330

FAX: (09) 276-5602

BALSTON AIR DRYERS/CO REMOVERS AND CLEAN AIR PACKAGES FOR FTIRS AND OTHER INSTRUMENTS

Wilton Instruments have been appointed exclusive distributors for Balston's Air Dryers/CO Removers and Clean Air Packages which are specifically designed to provide compressed air with pressure dewpoint at -73.3 deg C. CO content less than 2ppm, completely free of suspended liquids and particles larger than 0.01 m. They are more convenient and

more economical than gas cylinders and provide a constant purge at high flow rate 24 hours a day and 7 days a week. As the purified air is very dry, the ion beam splitter of the FT-IR Spectrometer is protected from corrosion. They provide a cleaner baseline in a shorter period of time. While the major uses of these products are in purging FT-IRs, Balston also provide Gas Generators for Zero (Hydrocarbon free) Air, Nitrogen and Hydrogen for use with Gas Chromatographs and other analytical instruments. A generator is also available for use with TOC Analyzers.

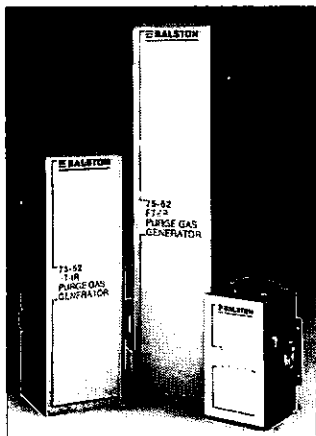

For further details contact:

Wilton Instruments

P O Box 31-044

LOWER HUTT

PH: (04) 5697-099

FAX: (04) 5697-240

ICI DISCONTINUES "NEUROMATE"

In June this year ICI Instruments discontinued the recently released Automatic Catecholamine Analyser titled "Neuromate".

NEW: SHIMADZU FITTINGS KIT NOW AVAILABLE

The new Shimadzu fittings kit contains fittings and tubing tailored for

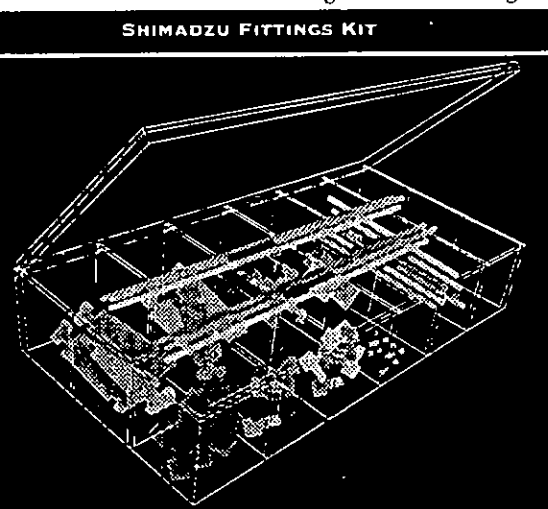

your Shimadzu HPLC system with a Rheodyne injection valve. All the fittings and tubing required for the proper operation of your system can be found in one inexpensive, convenient kit.

Upchurch Scientific has specific system fittings kits for ABI/Kratos, Bio-Rad, Bechman, Gilson, Hewlett-Packard, Hitachi, LDC/Milton Roy, Perkin Elmer, Rainin, Spectra-

Physics, Varian and Waters systems. Many of our fittings kits can be used with multiple systems. If your particular system is not listed or

For more information on any of the above fittings kits contact:

Douglas Scientific

PH: 09 837-5447, FAX: 09 837-5446, P O BOX 45-027

AUCKLAND 8

OUTSIDE AUCKLAND FREEPHONE: 0800 735 725

BOTTOM-OF-THE-BOTTLE SOLVENT FILTER IS DESIGNED TO USE ALL OF THE SOLVENT AVAILABLE IN YOUR RESERVOIR

Upchurch Scientific has designed this filter to use ALL of the solvent available in your reservoir, saving you money on your expensive HPLC solvents. Unlike other filters which generally draw from the top, our

expansion cone goes clear to the bottom of the filter allowing solvent to be drawn to within .06" of the bottom of the filter. This allows you to draw further down which allows for more efficient use of your solvent. Because the filter is disposable, big savings will be realized. Simply loosen the lock nut, pop off the low cost filter cup and replace it with a new economical one. The A-550 system is completely reusable! Our new filter has a 5/16"-24 standard flat bottom hole. The nut and ferrule is molded for PEEK material and the seal is molded from Tefzel. Depending on what filter assembly you buy, it can be used with either 1/8" or 3/16" tubing. When fully assembled, the filter is 1.850 inches long and without the nut and ferrule, the filter is 1.22 inches long.

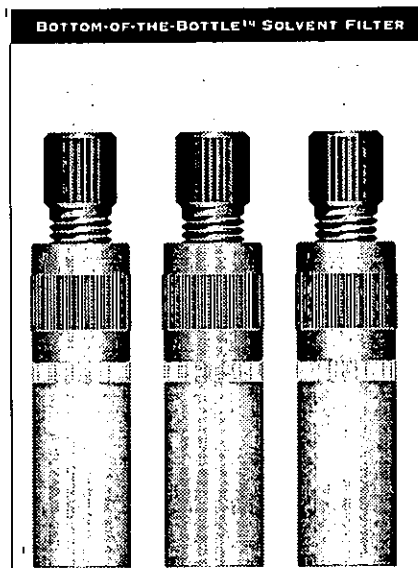

For more information on the Bottom-of-the-Bottle Solvent Filter contact:

Douglas Scientific

PH: 09 837-5447, FAX: 09837-5446,

P O Box 45-027, AUCKLAND 8

OUTSIDE AUCKLAND FREEPHONE: 0800 735 725

ACCURATE

Until now, flow rate measurements were more of an art than a science. Using an old-fashioned bubble meter, each measurement required the user to take multiple readings and average the results. Simply adjusting a gas source to a specified flow rate meant even more time, work and frustration.

The J & W AccuRATE

1000 Intelligent Flowmeter replaces tedious bubble-type methods with smart electronics that measure flow rates instantly. Continuously. It

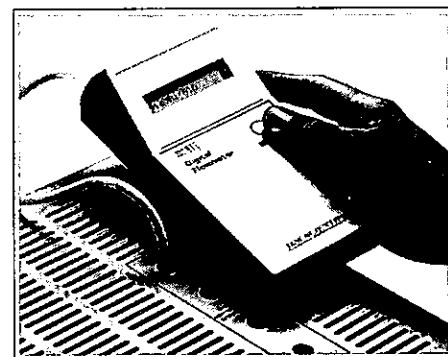

STOP PRESS

In order to better serve customers outside of Auckland **Douglas Scientific** have acquired a **TOLL FREE NUMBER**.

Ring **0800 735 725** for any information you need on chromatography, spectrophotometry and the wide range of scientific instrumentation they are able to supply.

Normal contact details are:

Phone: (09) 837 5447 Fax: (09) 837 5446

PO Box 45-027, Auckland 8.

BIO-RAD IS FIRST IN FT-IR

Molecular identities emerge quickly and easily with state-of-the-art FT-IR spectrometers and accessories.



Bio-Rad makes the FTS 60A, with the 896 interferometer, the only FT-IR with precision step scan operation, TRS and 2D IR.



Bio-Rad makes the Tracer, the first GC/IR with real-time picogram sensitivity.



Bio-Rad commercialized the FT-IR microscope, and now offers the UMA 500 research system with fingertip controls.



The new Bio-Rad FT-Raman spectrometer is the first to offer precision step-scan capability.

If FT-IR spectroscopy is critical to the outcome of your research, you must evaluate Bio-Rad first as a source of versatile, high performance FT-IR spectrometers and accessories. For more information on the above instruments, call 0-9 443 3099 or Toll Free: 0800 805 500, Fax: 0-9 443 3097 or write: Bio-Rad Laboratories Pty Ltd. PO Box 100 051, Auckland 10.



The FTS 60A with the acclaimed 896 interferometer

BIO-RAD Digilab

makes checking and setting rates fast and easy. Even split flow ratios are a snap. And it works with all non-corrosive gases, so it's versatile enough for any lab. Best of all, there's no glassware to shatter, no readings to average, no stopwatch to read...no bubbles to blow.

For more information contact:

Douglas Scientific

PH: 09 837-5447, FAX: 09837-5446,

P O Box 45-027, AUCKLAND 8

OUTSIDE AUCKLAND FREEPHONE: 0800 735 725

ELGA

Douglas Scientific are pleased to announce their recent confirmation as the **Exclusive Distributors** for the **ELGA** range of laboratory water systems in New Zealand.

Elgastat laboratory water systems are complete packages capable of selectively providing one or two grades of high purity water from one system in convenient volumes.

The systems have been developed to satisfy the pure water requirements for the entire range of laboratory activities, from washing glassware through to use in the trace analysis of metals and organic compounds.

Douglas Scientific in conjunction with ELGA will be announcing a new Ultra pure water system in the next issue of this magazine.

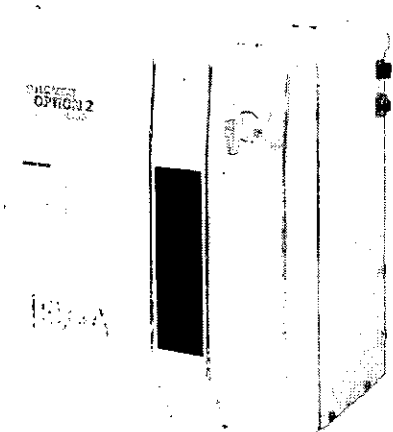

ELGA OPTION SERIES

A REAL OPTION FOR THE ENERGY CRISIS!

The ELGA Option range of laboratory water systems address a very topical need and fulfil long term requirements for economical, high quality laboratory water. Consider for a moment the electricity consumed in producing 20 litres of water by still. Consider also the amount of cooling water flushed straight down the drain.

By comparison the ELGA Option series based on Reverse Osmosis technology produces purer water, when needed, at a fraction of the cost and resource wastage. Even with the capital costs of the unit it makes sense to replace your still with an option unit - financially AND environmentally.

For more information on these products contact:

Douglas Scientific

PH: 09 837-5447, FAX: 09837-5446,

P O Box 45-027, AUCKLAND 8

OUTSIDE AUCKLAND FREEPHONE: 0800 735 725

Advertising Works

 **Chemistry**
IN NEW ZEALAND

Your Publication

ADVERTISING: Carl Roze, Ph: 0-9-521-5151
COMMERCIAL EDITORIAL: Roger Whiting,
Ph: 0-9-377-3570

Continued from page 55

you talked with farmers recently or accountants, doctors, engineers or viticulturalists etc, etc. The so called malaise seems to be everywhere and yet there are many individual success stories. Crazy people who decide to swim against the tide or make a stand to do it themselves.

Every generation has had to sort out its priorities and take hard decisions as to where the future is heading and what measures are needed to obtain advantage and make progress in the new directions that are opening ahead of them.

We as a group of chemists should not expect to be exempt from the necessary rethinking that is part and parcel of life. The secret to success seems to be that we need to be part of the decision making process and to have a vision of the future. To be pro-active is better than being reactive and yet chemists seem slow to develop these skills and wish to remain with the "comfort" of the status quo. Is the future for the NZIC to link or merge ourselves with another off shore group of chemists with similar problems to our own?

My own opinion based on many discussions during my recent tour of branches is that we need an injection of new concepts and ideas and to broaden our horizons by interacting more with other science workers. My belief is that the time is now here when we should decide if the NZIC as a Society for the promotion and practice of chemistry needs to look at being the originator of a larger and more welfare based society for the benefit of all science workers.

It is clear that Cabinet Ministers expect scientists to be involved with all areas of science planning and have set up structures to enable this to happen but it is also clear that reasoned collective arguments are more likely to succeed in the future.

If the institute reorganised to co-operate with teachers, researchers, industrialists, CRI's and private sector workers in all branches of the sciences many of the smaller associations would gain access to information and support which is now out of their reach. The large membership would mean lower fees and increased benefits. The fragmented and often competitive nature of conferences, overseas visitor schedules, lobbying of political systems, distribution of news of personal interest about individuals, information and technology transfer etc would become co-ordinated and cost efficient. Because this group would be broadly based its ability to be actively involved in science education at school level would be greatly enhanced.

The vexed issue of each societies journal or newsletters could be better dealt with if many of them were combined into say two or three publications making advertising revenue more likely and printing/distribution costs more attractive.

We have the Royal Society as the Learned Society for Science in New Zealand with its many facilities for publication of papers and potential to conduct conferences, reflect on science policy and direction etc. Academic outlet is often via these areas at present and not through the publication of member bodies of the Royal Society.

It is a fact of life that the future will happen with or without the input of chemists. Our exciting Institute structure is becoming less able to survive as the pure chemist becomes rare and as career structures become less defined and flexibility to tackle anything is almost demanded by employers.

Before rushing off to amalgamate with Chemists in Australia let us first explore the option of co-operation with the other sciences at home to provide a strong base for young scientists leaving the educational institutes to join and contribute to the promotion of science of which chemistry is an integral part.

Can the NZIC survive on its own? On present trends the answer would have to be that we have a few years at most. As members seem to be hard pressed to decide how to resolve this problem I see the above concept as the main option left at this stage. Our only remaining outcome will be merger with Australia.

CHEMISTRY IN NEW ZEALAND

The official journal of the New Zealand Institute of Chemistry

ADVERTISING RATES

Effective June 1992

PUBLICATION SCHEDULE

20th day of February, April, June, August, October, December. Plus Annual Year Book - May

CIRCULATION

Chemistry in New Zealand is posted to all members of the NZIC, advertisers, companies included in the Yearbook, educational institutes in NZ and overseas. Total (2000 plus)

READERSHIP PROFILE

Fully qualified, professional people, working in key roles throughout NZ Industry, including:

- Consultants • Universities & Tech Institutes • Crown Research Institutes • Chemical Industry • Paint Industry
- Cosmetic and Pharmaceutical Industry • Plastics Industry • Detergent Industry • Pulp and Paper Industry
- Fertiliser Industry • Veterinary Products • Environmental Monitoring

EDITORIAL

Editorial policy is to publish articles relevant to readership profile with particular emphasis on NZ based chemical research, political and regulatory developments in science and science based industries. Room is also devoted to articles on commercial developments in the science and chemical industries. E.G New products, agencies, plants.

EDITORIAL FEATURES

- August* - AGM. In spectroscopy - F T I R
- October* - Company Profiles - Thermal analysis
- December* - Data acquisition systems and auto samplers
- February '93 - Spectroscopy UVVIS & A A**

RATES : 1992 <i>All rates PLUS GST</i>	Size	6x	3x	Casual
	Full page 4 Colour	1300	1400	1500
	Full Page Black & White	735	840	950
	Half Page	430	490	550
	One third Page	330	390	440
	Quarter Page	275	320	370

Additional Charges:	
Spot colour : \$185 per col	Inside Front - \$95
Specified Positions:	Inside Back - \$75
Front cover - \$160 (Special Conditions incl Cover Story)	Special positions - \$70
Back cover - \$110	Inserts - \$305 (per page)

SPECIAL ADVERTORIAL OFFER:
Front cover plus one full page of Editorial - \$2,100.00 This includes copy writing.

For specific Editorial opportunities contact the commercial Editor.

EDITOR: Mr Ron Hall, Phone 09 534-9109
COMMERCIAL EDITOR: Mr Roger Whiting, Phone 09 377-3570
ADVERTISING: Mr Carl Roze, Phone 09 521-5151

Publisher: Michael Pervan Holdings, A Division of: Promotional Options Limited P O Box 101-189 N S M C. Auckland 10

YEAR BOOK AMENDMENTS

The publishers wish to apologise for some inaccuracies which have appeared in the 1992 Chemistry in New Zealand Yearbook. The entry for **SCITECH** was missed and should read as follows:

SCITECH

Science & Technology (NZ) Ltd
PO Box 663, DUNEDIN
Phone: 0-3 477 7860 Facsimile: 0-3 477 7870

PO Box 5104, CHRISTCHURCH
Phone 0-3 383 1146 Facsimile 0-3 383 1149
Mobile: 025 329 302

PO Box 44004, LOWER HUTT
Phone: 0-4 566 6096 Facsimile 0-4 566 6097
Mobile: 025 440 781

PO Box 23-611, AUCKLAND
Phone: 0-9 270 3332 Facsimile 0-9 270 3333
Mobile: 025 329 301

Distributors of a wide range of scientific and medical instrumentation and accessories. Customers are supported with service in each main centre to provide solutions to their scientific problems.

SCITECH are exclusive agents for the following brand names:

- Linear
- Bruker
- Biochrom
- LKB
- Biochrom
- Wallace
- IEC
- Queue
- Glaswork Wertheim
- Isopach

SCITECH also represents: J & W Scientific and Upchurch.

The purchase by **DOUGLAS PHARMACEUTICALS** of **SCIMED** division of Zenith Technology was missed. Sci Med division of Zenith Technology is now incorporated into **DOUGLAS SCIENTIFIC**. Also missed from the Douglas listing was their representation of Shimadzu scientific instruments, which is one of their leading brands. Consequently, there was no mention of Douglas Scientific's involvement in:

- High Performance Liquid Chromatography
- Gas Chromatography
- Scanning Densitometry
- GC Mass Spectrometry
- FT-IR Spectrophotometry
- UV-VIS Spectrophotometry
- Atomic Absorption & ICP Spectrophotometry
- Fluorescence Spectrophotometry
- Balances
- Environmental testing instruments including TOC
- Physical testing equipment
- Thermal Analysis
- Biotechnology instrumentation

Several Of **RADIOMETER PACIFIC'S** Agencies were incorrectly assigned to other companies. Radiometer Pacific represents the following brands:

Solea Tacussel

Kubota Electrochemical Instruments — Centrifuges

Hareus Original Hanau — Instruments, Lamps & Burners

Retsch GMBH — Sample Preparation Equipments

Sympatec GMBH — Particle Sizing Systems

Milestone — Microwave Digestion Systems

Resona Technics — Rotary Evaporators

Radiometer Pacific supply the following equipment

- Incubators
- Astell
- High Pressure Reactor Vessels
- Environmental Chambers - Heraeus Votsch
- Karl Fischer Titrators - Radiometer Copenhagen.

NEW ZEALAND PHARMACEUTICALS address was incorrect and should read as follows:

NZP

New Zealand Pharmaceuticals Limited
PO Box 1869, Palmerston North, New Zealand
Phone: 0-6 325 8676 Facsimile: 0-6 325 8698

NEW PROGRAMMES IN SCIENCE FOR 1993

- Diploma in Applied Science
- Advanced Certificate in Applied Science

Part-time or full-time students. Entry can be from sixth or seventh form.

For students with no science background bridging courses are available.

Contact the Faculty Office, phone 307 9999, ext 8770, fax 307 9973, or the Information Centre.

All enrolling students must provide proof of age and citizenship or residency status.



**AUCKLAND INSTITUTE
OF TECHNOLOGY**

Te Whare Tahiriura O Tamaki Makau Rau



FOURIER

TRANSFORM YOUR LAB!

SHIMADZU FTIR SPECTROPHOTOMETERS



Shimadzu FTIR-8000 series are rugged, reliable, eminently usable spectrometers with a wealth of standard features:

- Exceptional expandability and ease of use.
- Unique mirror movement mechanism contains no frictional parts, assuring long-term optical stability.
- HELP functions and expert system type user guide facilitate easy operation even by inexperienced users.
- Multitasking system allows foreground/background operation.
- Experienced service and applications support.

For further information contact:

Douglas Scientific Ph: 0-9 837 5447, Fax: 0-9 837 5446. PO Box 45-027 Auckland 8.

 **SHIMADZU** and **DOUGLAS** Scientific

Name:	_____
Address:	_____
Phone:	_____ Fax: _____

HAZARDOUS AND LIQUID WASTE MANAGEMENT

Are you satisfied with your company's waste disposal practices?

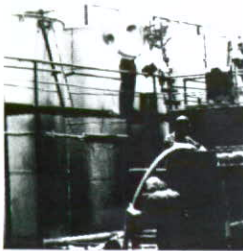

Managing hazardous waste is an increasingly difficult and complex challenge and is a continuous process of responding with technology to the challenges posed by technology.

In addition to our New Zealand services to manage solid waste, Waste Management NZ Ltd has since 1985 operated a hazardous/liquid waste treatment facility in Manukau City.

Waste Management NZ Ltd is committed to the complex, on-going process of challenge and response necessary to ensure the safe and effective management of hazardous wastes.

Today, our services include:

- | | | |
|--------------------------------|---------------------------------|---------------|
| ■ Waste removal and transport | ■ Emergency spillage response | ■ Consultancy |
| ■ Waste treatment and disposal | ■ Sample retrieval and analysis | ■ Recycling |



WM Waste Management N.Z. Ltd.



If you have a specific waste disposal problem, or an ongoing need for hazardous/liquid wastes treatment and disposal - or if you just wish to know more about us, clip this coupon and post to:-

- Hazardous/liquid Wastes, 25 Diversey Lane, Wiri. PO Box 76108, Manukau. Ph: 0-9 278 3644, 0-9 278 2433. Fax: 0-9 278 1975
- Box 356, Rotorua, Ph: 073 490 222. Fax: 073 461 659

Name	_____
Address	_____
Ph:	_____

FUME MANAGEMENT

BY THERMOPLASTIC

Dedicated to Laboratory Safety

Backed by many years of research and development, all our fumecupboards fully meet New Zealand Safety Standard 7203. Xtracare also meets New Zealand Standard 6101 part 3, and is classified as NON-HAZARDOUS.



LABROCARE—Added Operator Protection
Available in three sizes:

Model	Height	Width front to back	Length
LAB4	1550mm	760mm	1220mm
LAB5	1550mm	760mm	1525mm
LAB6	1550mm	760mm	1830mm

The Labrocure Fumecupboard has been specifically designed in New Zealand to meet situations which do not call for the advanced performance of the Xtracare. Built to the same internal height of 1550mm it offers the advantage of being able to set up taller laboratory equipment. It has the same slimline columns which both reduce turbulence and give more working space, and the same by-pass system to balance air intake. Fume containment is excellent. A full range of labtraps can be fitted to the ergonomic front beam. Baffles can be easily removed for cleaning and the recessed floor in Fridurit Resistex, Techdek or Stainless Steel looks after spillage. Made of quality materials throughout. Labrocure comes with sealed overhead lighting and doors with armour toughened glass or acrylic as an option.

Thermoplastic Engineering Ltd, produce fumecupboards to handle perchlorates, radio isotopes and a wide range of solvents. Additionally they produce a special model for schools. All Thermoplastic fumecupboard models can be made to special sizes as required.



ECONOCARE II
The ALL-Purpose Fumecupboard... designed in New Zealand by Thermoplastic to meet New Zealand Standard 7203 and specifically for the New Zealand laboratory environment, suitable for positioning on standard 900mm high laboratory bench unit

Model	Height	Width front to back	Length
ECON4	1220mm	760mm	1220mm
ECON5	1220mm	760mm	1525mm
ECON6	1220mm	760mm	1830mm

The new improved ECONOCARE II is constructed of high quality PVC. It features a single opening inlet. The bypass system and the vertical slimline side columns which reduce internal turbulence combine to provide balanced air velocity. All joints are PVC welded for increased chemical resistance. (After 21 years experience it is Thermoplastic policy to avoid stainless steel sheet or powder-coated aluminium in body construction. Stainless steel is however one of the four options for the work surface, the others being Fridurit, Resistex and Techdek.) Armour toughened glass doors or acrylic are options. Fume containment is excellent as is the sealed overhead lighting, while the ergonomic front beam can accommodate a full range of laboratory taps as required. Removable baffles make for ease of cleaning.

THERMOPLASTIC Xtracare

Microprocessor control

Designed for greater safety, simplicity and ease of operation, Xtracare meets New Zealand Standard 7203 and 6101 part 3 more comprehensively than any other fumecupboard on the New Zealand market. It is close to the ultimate in safe performance.

Other important features are
Heat resistant FRIDURIT ceramic floor as standard. Completely resistant to practically all chemicals. (Test data available.) Alternative floors in Resistex, Techdek or Stainless Steel. Recessed floors contain spillage.

Patented baffle system for increased fume containment. Baffles easily removed for cleaning.

New design of roof outlet to provide more even air extraction. Full width exhaust outlet.

Condensate trap to prevent condensation in ducting from returning to fumecupboard.

Ergonomically designed base beam for ease of tap operation. Full range of lab taps can be fitted.

Available in three sizes

Model	Height	Front to Back	Length
XTR4	1550mm	760mm	1225mm
XTR5	1550mm	760mm	1525mm
XTR6	1550mm	760mm	1825mm

SPECIAL SIZES MADE TO ORDER

Slimline angled columns to reduce turbulence.

Redesigned armour toughened 2-part glass doors...smooth, quiet...opening to 900mm high...automatic lock reset.

Gas and water services rear-mounted to give a much greater and clearer working surface.

Sealed overtop lighting delivering in excess of 400 lux to the working surface.

Phone or Fax for immediate information about any Thermoplastic product or service.



Pacemakers in Plastic Fabrication

Thermoplastic Engineering Ltd.

151 PARK RD, MIRAMAR, WELLINGTON, NEW ZEALAND, P.O. BOX 15-174, WELLINGTON. TEL: (04)388-2092. FAX: (04)388-7523